

Essential Instructions (LM0086X)

Lemon 7-channel Telemetry-enabled Stabilized Receiver with Text Display

Description	1
Setting Up the LM0086X Receiver.....	2
Step 1: Powering the Receiver	2
Step 2: Binding the Receiver	3
Step 3: Setting Failsafe.....	3
Step 4: Activating Stabilization	4
Step 5: Using Stabilization	7
Using Telemetry.....	12
Factory Reset the Receiver	13
Appendices	14
Appendix 1: Setting Up Text Display with EdgeTX	14
Appendix 2: Meaning of the LM0086 Receiver LEDs	14
Appendix 3: Understanding Throttle Lock	15
Appendix 4: Troubleshooting Text Display	16

This document is specifically tailored to the LM0086X receiver. For instructions relating to the earlier LM0086, which did not have the Text Display programming feature, here is the download link:

<https://www.rcgroups.com/forums/showatt.php?attachmentid=16965449&d=1676162451>

Description

The Lemon Rx LM0086 Seven-channel Stabilized Receiver is a full range DSMX/DSM2™-compatible receiver, part of Lemon’s Generation 2 line. It combines full-range telemetry functions with the well proven Lemon rate stabilizer technology to iron out the turbulence.

The Lemon stabilizer is small and light. Despite its low cost, it offers long range and high performance with its “dual diversity” antenna system. A Lemon DSMP satellite receiver can be added to enhance signal reliability but is not normally required.

The slim line case, seven available channels and built-in barometric sensor will be particularly attractive to glider pilots requiring a compact package.

The receiver automatically switches mode between DSMX™ and DSM2™ as required.

The LM0086 works with virtually any programmable Spektrum transmitter, including the first- and second-generation DX series, as well as the newer NX and iX transmitters. It also works with open-source transmitters using an add-on DSM2 or DSMX compatible module, as well as with Multiprotocol transmitters such as RadioMaster TX16S. Telemetry is available if supported by the transmitter.

Despite being labelled a 7-channel receiver based on the number of available control channels, the LM0086 also provides stabilizer Master Gain on channel 8. Thus, an eight or more-channel transmitter with voice capability is required to allow use of all the available functionality, but configuration options allow operation with radios having fewer features or channels.

The original version of the LM0086 used LEDs and buttons for programming. The new version, introduced in August 2024 and referred to as the LM0086X, added the Text Display feature to simplify programming, but it also retains the earlier lights and buttons programming approach as an option.

Other versions of the receiver with 10 control channels and separate power input pins are also available.

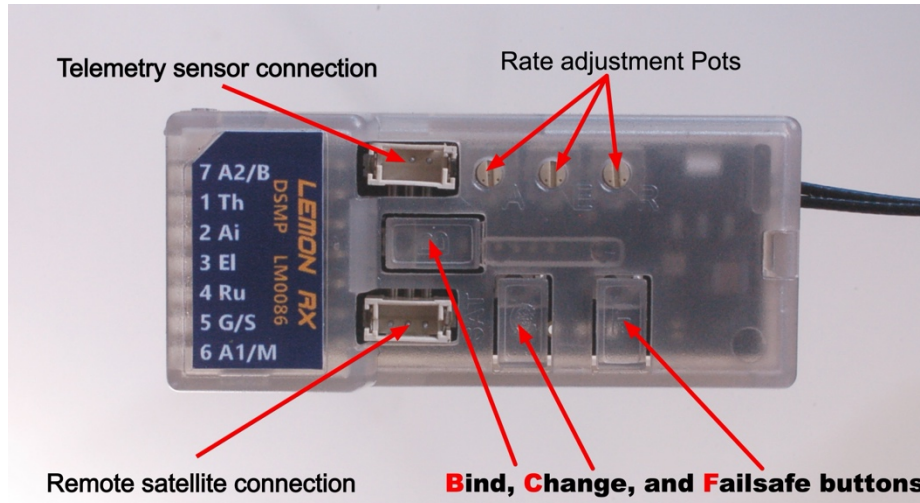

Connections

The receiver has seven sets of pins on one end of the case: channels 1-6 are arranged in the usual Spektrum order of TAERGAux1. The channel 7 pins (Aux2) can also function as a normal bind plug connector and are labelled A2/B accordingly. Channels 5 and 6 pins can be used for setting up the receiver (hence the G/S and A1/M labels) but these options can be ignored if Text Display is used. In addition, there are connectors for an optional satellite receiver and either an optional voltage/current sensor or a simple voltage probe for telemetry. Note that channel 1 is the **second** set of pins and that the satellite and sensor connectors are identical but labelled. Don't mix them up. The receiver has a built-in barometric sensor which can provide altitude and vertical speed (vario) data.

As delivered, the Lemon 7-channel receiver has stabilization disabled and no internal mixes set. **Out of the packet it functions as a standard seven channel DSMX/DSM2™-compatible receiver.**

To use the receiver without stabilization, the only setup you might want to do is to change the default No-pulse failsafe to User-set, as explained in Step 3 on page 3. In the unstabilized state, any other required programming, such as mixes, will be done in the transmitter, as with other regular receivers.

Setting Up the LM0086X Receiver

Step 1: Powering the Receiver

The receiver requires a power supply between 4.0v and 8.5v that can deliver the required current to the servos without dropping below 4v. The most common source is likely to be an ESC (Electronic Speed Controller), which will typically supply 5v or 6v to the receiver and servos. Most electric powered planes will use this arrangement, and power will automatically be provided through the Throttle connection to channel 1; however, any of the sets of channel pins can be used to supply power to the receiver.

Step 2: Binding the Receiver

To bind the receiver to a specific model memory in the transmitter, use either of these two methods:

Binding Using the Bind Button

1. Power ON the receiver (with satellite receiver connected, if used).
2. Hold down the Bind button B for about 3 seconds.
3. Release button B when the red Receiver Status light starts to flash.
4. If a satellite receiver is used, power cycle the receiver at this point by removing power and applying it again. Both the receiver status light and the satellite light will then flash.
5. Proceed to bind to the transmitter in the normal way (see transmitter instructions).
6. Bind is complete when the red Receiver Status light (and satellite light, if connected) are solid.

Binding Using a Bind Plug

(The traditional Spektrum™ method)

1. With receiver power OFF, place a bind plug on the channel 7 pins.
2. Power ON the receiver (with satellite receiver connected, if used).
3. The red Receiver Status light and satellite, if connected, will start to flash.
4. Proceed to bind the transmitter in the normal way (see transmitter instructions).
5. Bind is complete when the red Receiver Status light (and satellite light, if connected) are solid.
6. Don't forget to remove the bind plug.

The receiver is now ready for use with stabilization inactive; however, adding User-set failsafe is recommended.

Step 3: Setting Failsafe

No-pulse mode is the default response of the receiver as supplied if signal is lost for approximately 1 second or more. The receiver then ceases to send pulses on any channel. Servos stay in their current positions, while the ESC, after a brief delay, will normally shut down power to the motor.¹ By contrast, the User-set failsafe option causes the receiver on loss of signal to send a pre-set value to each of the servos and the ESC.

No-pulse failsafe is adequate for most electric powered models. User-set failsafe is often preferred, however.

To activate User-set Failsafe, proceed as follows:

1. Power ON the transmitter. Set sticks and switches to the positions required on loss of signal.
2. Power ON the receiver.
3. **After 3 seconds but within 60 seconds** of powering ON the receiver, press and hold the Failsafe button F.
4. Release button F when the green Setup LED turns ON, showing that the receiver has registered the failsafe values.
5. Test failsafe (carefully) by turning off the transmitter (on the bench, not in flight!).

The receiver will retain the failsafe values until the procedure is repeated or the receiver is reset.

To cancel User-set Failsafe:

1. Power ON the receiver. If User-set Failsafe is active, the green Setup light will be ON.
2. **After 3 seconds but within 60 seconds** of power ON, press and hold button F.
3. Release button F when the green Setup LED turns OFF, indicating No-pulse mode.
4. Alternatively, you can cancel User-set Failsafe in the Text Display Setup menu.

¹ Some ESCs may behave differently; be sure to test yours.

Setup, if you are not wanting to use the stabilization function, is now complete.

Just a check: stabilization is **not** active if **none** of the red programming LEDs R1, R2 and R3 is lit (see the diagram under “LED Identification” on page 4). This is how the receiver is delivered.

Step 4: Activating Stabilization

The following assumes you are using a Spektrum Generation 2 or later programmable transmitter with the most recent AirWare version. Compatible radios can also be used.

Programming the Receiver

For the LM0086X, programming the receiver to activate stabilization can be done in either of two ways: (1) with Text Display, using the transmitter to display and adjust the various settings, or (2) the older way, using LEDs and buttons on the receiver. In most cases, the Text Display method is easier. If you decide to use the LEDs and buttons method, however, please refer to the LM0086 instructions available from:

<https://www.rcgroups.com/forums/showatt.php?attachmentid=16965449&d=1676162451>.

Activating stabilization requires programming the receiver, as explained below. Note that if stabilization is active, certain mixes, notably Delta Wing (elevons) and V-Tail, **MUST** be done in the receiver, not in the transmitter. **This is NOT an option**, as transmitter programming of such mixes will likely cause a crash.

WARNING: If doing any programming of an electric powered model with the motor connected, please remove the propeller for your safety!

LED Identification

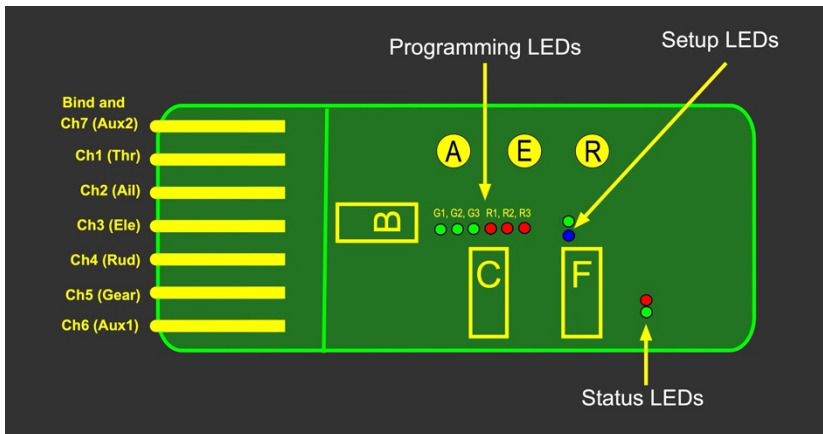

Although with the LM0086X you will be doing programming primarily via Text Display, it's still important to understand the LEDs in order to verify the receiver setup. This diagram, together with the one on page 2, identifies the buttons, pots (potentiometers) and various indicator LEDs. Please review them carefully.

With the receiver powered ON, locate the three green and three red programming lights (G1, G2, G3 and R1, R2, R3). Press button C for no more than 2 seconds to identify these lights.

Also locate for future reference the position of the blue and green Setup lights and the red and green Status lights.

Individual stability gain adjustments for Roll (Aileron), Pitch (Elevator), and Yaw (Rudder) are done with the three rotary “pots” labelled A, E and R in the diagram.

The meaning of the various LEDs is explained in Appendix 2 on page 14.

Programming Stabilization with Text Display using a Spektrum Generation 2 or higher radio

Text Display is an enhancement to the firmware of Lemon telemetry receivers (7- and 10-channel). It allows you to see and change the settings of the stabilizer on the screen of your transmitter, rather than relying on lights and button-pushing, and is particularly useful when setting up gains, checking the stabilizer response direction, and identifying what mixes are currently set.

LEMON RX

Pot A-E-R: 51 50 50	←	The gains of the 3 onboard pots Aileron, Elevator, Rudder in %
Mode: Rx Only	←	Mixer mode: NT, DT, VT, Rx Only
FS:On TL:On	←	Failsafe and Throttle Lock
StbSw: C7(A2)	←	Stab switch on channel 5 or 7
Dir A-E-R: RNN	←	Stab response direction Normal or Reversed
Always-ON:Off	←	Always on or not
M.Gain %: 75	←	Value of Master Gain in %

Setup Mode Screen

The initial screen, shown above, displays basic information but does not allow it to be changed. To make changes, you must put Text Display into Setup Mode.

To enter Setup Mode, **first ensure that channels 1-4 (T, A, E, R) provide ± 100% output and are controlled by the two sticks**. Check the transmitter Monitor screen to verify that this is the case. Note that transmitter stick Mode and Channel Order are irrelevant for this purpose.

Power up the receiver (with or without servos connected). **Within 60 seconds after the receiver is powered up, hold the two transmitter sticks in the lower outside corners of the gimbals for a few seconds.**

The Lemon RX display should become something like this one.

LM Rx Setup

```
1-Chg Dir Ai
Mode: NT+DuA
StbSw: C7(A2)
FS:Off TL:On
Always-ON:Off
Dir A-E-R:RNN
```

The first line with the number indicates what you can change. In this case the response direction of the Ailerons.

The rest of the lines are the same as the basic Lemon Text Display and show the current settings.

You **change** the value of the item displayed on the first line by moving the Elevator stick fully up or down. In the example shown the Aileron response direction will toggle between Normal and Reverse each time you move the Elevator stick.

While you are in Setup Mode you can **select a different item** by moving the Aileron stick to one end. Moving the Aileron stick one way increments the screen number, the other way decrements it. The second screen then appears. Now you can **change the value** of the item by moving the Elevator stick up or down.

LM Rx Setup

```
2-Chg Dir EI
Mode: NT+DuA
StbSw: C7(A2)
FS:Off TL:On
Always-ON:Off
Dir A-E-R:RNN
```

To summarize

Select the item you want to change by moving the aileron stick to one end. **Change** the value of the item by moving the elevator stick up or down.

Basic Screens Available in Setup Mode

Seven screens are initially accessible in Setup Mode. The first four directly change settings:

1. Change the direction of **roll** (Aileron) stab reaction.
2. Change the direction of **pitch** (Elevator) stab reaction.
3. Change the direction of **yaw** (Rudder) stab reaction.
4. Change between **single and dual aileron** channel stabilizer response.
5. **Show Config.**
6. **Exit and save** your settings.
7. **Exit without changing the settings.**

Advanced Screens Available in Setup Mode

Selecting Screen 5, "Show Config.", and moving the elevator stick up or down opens up advanced configuration options. The additional screens are as follows:

8. Change the stabilizer mode among **NT, DT, VT** and **Rx Only** (no stabilization).
9. Change the **stabilizer on/off switch** between channel 5 and channel 7.
10. Change to **Always On** stabilization. Check that the blue Status LED on the receiver lights.
11. Turn **Throttle Lock** ON or OFF. Most electric fliers should leave it ON. The OFF option is intended for fliers who use channel 1 for something other than throttle (see Appendix 3).
12. **Cancel User-set failsafe.** User-set failsafe can only be set using the F button on the receiver.
13. **Reset** the stabilizer to factory settings and reboot.
14. **Calibrate the voltage** probe wire or the voltage of the optional V/I sensor. See page 13 for reference.
15. **Calibrate the current** sensor of the optional V/I sensor. See page 13 for reference.

Depending on the receiver, a final un-numbered screen may appear that contains some system information and cannot be changed.

Exiting from Setup Mode

Assuming you want to save your settings, use the aileron stick to go screen 6 (Exit and save settings), then use the elevator stick to exit.

To exit without saving settings, go to screen 7 and use the Elevator stick to exit.

Step 5: Using Stabilization

The following assumes that you are using a Generation 2 or later Spektrum transmitter and that you have already programmed the receiver with one of the stabilization options explained above.

It is usually most convenient to complete receiver programming (see Step 4, above) and items 1 to 3 below before mounting the receiver in the plane.

1. Set up the transmitter

Set up a new model definition in the transmitter or reset an existing model. In particular, disable any delta wing (elevon) or V-tail mixing in the transmitter – if these mixes are required when stabilization is active, they must be done in the receiver. Make sure servo Travel (end points/limits) is set to 100%.

Set up a switch on channel 7 (or optionally on channel 5) to control Stabilization ON/OFF. Set up channel 8 (if available on your transmitter) to be controlled by a knob or slider for Master Gain.

2. Bind the receiver

Bind the receiver to the transmitter, as explained above (Step 2 on page 3).

3. Test the receiver

Power up the transmitter then the receiver. The red Status LED should be ON.

Check that the Stabilization ON/OFF switch works correctly. The green Status light on the receiver will be OFF if channel 7 is at 0% or 100%. If channel 7 is at -100%, It will be ON, indicating that stabilization is active.

Temporarily plug a servo into each of the Ail, Ele, and Rud outputs and check that they operate normally in response to the correct transmitter sticks. Power OFF.

4. Mount the receiver in the plane

The receiver can be mounted upright or inverted and must be aligned with the direction of flight. The servo connectors can be at the front or rear.

The receiver will not work properly if mounted across the fuselage, on edge, tilted forward or backward, or at an angle to the centre line. This receiver, unlike some other stabilizers, does not need to be mounted particularly close to the centre of gravity of the model.

Ensure that the active portions of the two main antennas (the silver section about 31mm long) are well separated from each other and from conductive items such as wiring, battery, and carbon fibre. They should be approximately at right angles to each other. Take care not to kink the cables.

The receiver must be firmly mounted to the structure of the aircraft with the double-sided mounting tape supplied or other vibration-absorbing material. It must not be able to wobble or come loose in flight. Hook-and-loop material can be used, but only if care is taken to ensure that the firm mounting requirement is met.

Given the dual diversity antenna setup of the Lemon receiver, a satellite receiver is not normally required, but can be used if desired for extra signal reliability. It should be well separated from the main receiver. Be sure you can access the three gain pots on the receiver, as you will need to adjust them, perhaps repeatedly.

5. Connect servos and speed control (ESC), set switches and wing type

Important safety warning: Leave the motor unconnected or remove the propeller when programming or testing an electric powered model. Electric models can bite!

Table 1 shows how the servos should be assigned to receiver channels and the corresponding LED display. Plug the servos and ESC into the appropriate slots on the receiver. Normally, the Stabilization ON/OFF channel slot (channel 7 by default or channel 5 if set as an option) will be empty, as it is used internally by the receiver.

Model Type	Channel Assignments								Wing Type	Stabilizer Red LEDs		
	1	2	3	4	5	6	7	8		R1	R2	R3
Conventional (one Ail channel)	Thr	Ail	Ele	Rud	*		On/Off	Master Gain	Normal	✓	✓	X
Conventional (two Ail channels)	Thr	RAil	Ele	Rud	*	LAil	On/Off	Master Gain	Dual Ail/ Flaperon	✓	✓	✓
Delta Wing (Elevons)	Thr	RElev	LElev	Rud	*		On/Off	Master Gain	Normal	✓	X	X
V-Tail (one Ail channel)	Thr	Ail	RTail	LTail	*		On/Off	Master Gain	Normal	X	✓	X
V-Tail (two Ail channels)	Thr	RAil	RTail	LTail	*	LAil	On/Off	Master Gain	Dual Ail/ Flaperon	X	✓	✓

* Channel 5 (Gear) is Stabilization ON/OFF on 6 channel transmitters; otherwise, it can be used as a normal servo output. Set wing type (in the Aircraft Type menu) as shown; in all cases, the tail type is Normal, even for a V-Tail model.

6. Verify control directions, adjust centring and servo throws

Power ON. Use the Stabilizer ON/OFF switch to turn stabilization OFF (green Status light OFF). Be sure you know which way is OFF in case you need to use it in a hurry!

With trims in neutral, adjust servo arms and linkages to align your control surfaces. Use only a minimum of subtrim on the transmitter for fine tuning. Servo arms should be at right angles to push rods to ensure equal movement in both directions.

Adjust transmitter reversing so that all servos work in the correct direction in response to the sticks. Note that where elevon, V-tail or flaperon mixing is involved it may be necessary to interchange the two servo connectors and/or reverse controls to get the correct action.

With travel (limits) and control rates at 100%, check that control surface throws are at the recommended maximums for the model and adjust linkages if necessary. Note that adjusting throws in the transmitter will not affect stabilization responses, so throws need to be set mechanically to give the stabilizer an appropriate amount of control; the exact amount is not critical, as gain will later be used to adjust stabilization, but it should be reasonably close.

7. Test stabilization response and directions

Turn the three on-board gain adjustment pots fully clockwise to maximize action.² Set the Stabilizer ON/OFF switch to ON (green Status light ON). Sharply move the plane in each of the three flight axes and verify that the control surfaces move momentarily to oppose the disturbance. See diagram below.

HINT: If you find it hard to see the response direction, put your finger on the hinge line of the control surface. It is easier to feel a short pulse than see it.

Direction of servo movement with changes in direction when stabilizer is enabled

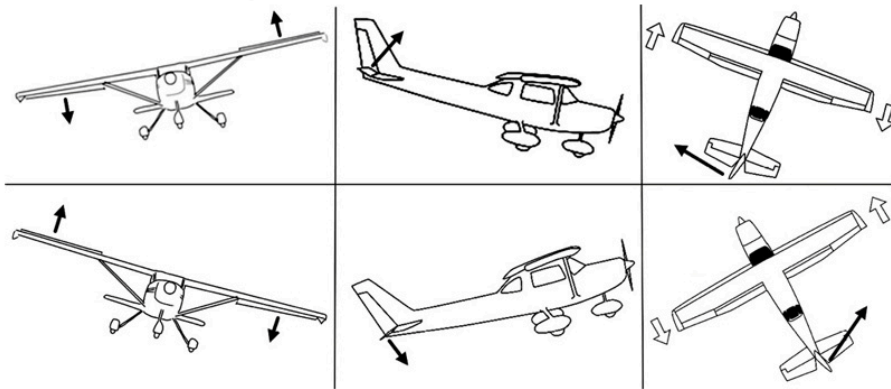

The diagram shows how the surfaces should respond with a momentary pulse when the model is moved about each axis. When the model is rolled sharply to the right, the right aileron should go down and the left aileron up, briefly, to resist the displacement. Likewise, when the model pitches nose-down, the elevator should go up briefly to compensate. And when it yaws nose-right, the rudder should go left for a moment before returning to neutral.

Remember that this receiver provides rate stabilization, not auto-levelling. Thus, when testing, the control surfaces will only be displaced while the model is being disturbed. As soon as angular motion stops, they will return to neutral. Hence, look for quick twitches of the control surfaces in the right directions, not prolonged control offsets.

² If you are using channel 8 for Master Gain, set it temporarily to the middle or high end of its range.

THE FOLLOWING IS VITALLY IMPORTANT:

If stabilization moves any of the surfaces the wrong way (i.e., to increase the disturbance), your model may be uncontrollable (until you switch off stabilization)!

To correct this, use Setup Mode described on page 6 to change the appropriate stabilization response direction indicated by the Text Display screen or three green LEDs: G1 (aileron), G2 (elevator) or G3 (rudder).

Just as experienced RC pilots check stick directions before the first flight of the day, so a pilot using a stabilizer should regularly check that the surfaces move correctly in response to a disturbance.

9. Set dual rates and expo in the transmitter

With the control surfaces set to move in the correct directions and with the full throws recommended for your model, you can now adjust the response to transmitter stick inputs by setting dual rates (D/R) and expo.

A good starting point for D/R is to set High Rate to 100%, Mid-Rate (if available) to 80-85%, and Low Rate to 65-75% for each axis. Expo of around 20% softens response around neutral and can make smooth flying easier. These settings can be adjusted to your liking after the initial flights.

Stabilization settings also affect the response of the model to transmitter input, typically somewhat reducing sensitivity with an expo-like effect.

Note that the dual rate and expo settings in the transmitter determine stick response but **don't affect** how stabilization works. That is entirely done within the receiver.

10. Adjust the stabilizer gain pots

As delivered the stabilizer gains are normally at the 12 o'clock position. For first flights set the three gain pots at about the 10 o'clock position. This is a good conservative starting point that should produce noticeable stabilization. For most models, at least one or two gain adjustments will be needed during flight testing to achieve optimum stabilization.

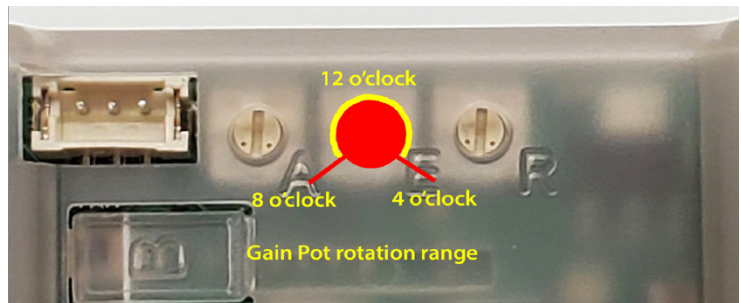

11. Prepare for flying

Check that the balance of the model is correct according to the manual.

Check the control directions and stabilization functions one more time.

Do a reduced-power range test as directed in the transmitter manual (should give at least 30m/100 feet range with full control).

Check that the switch is operating correctly to turn stabilization OFF (red Status light only) and ON (green and red Status lights). Yet again, make sure you know which way is OFF!

Test failsafe operation by running the model (well secured) at about half throttle and turning off the transmitter. With the default No-pulse setting, the motor of an electric-powered model should stop after a couple of seconds and the control surfaces should stay in their current positions. User-set Failsafe (as described in Step 3 on page 3) moves ALL channels to pre-set failsafe positions. This may be preferred for an electric model and is mandatory for an IC (fuel-powered) model.

If you have Master Gain (channel 8), check that it is set it to the middle of its range and that increasing the control knob or slider increases the resulting stabilizer reaction. Reverse the channel output if not.

12. Test fly

For safety, always start a test flight with the stabilizer turned OFF (green Status light OFF).

Power ON the model.

Take off and fly around, adjusting trim as necessary to make sure the model flies properly without stabilization. If trim is very far off neutral, land and make mechanical adjustments.

When satisfied, and at a safe height, turn the stabilizer ON. If the model rolls, dives or turns suddenly, at least one of the gyro directions (LEDs G1, G2, G3) is incorrectly set. Switch OFF the stabilizer immediately! Land and fix.

Likewise, if you encounter major oscillation, usually in high-speed flight, either land and reduce gain on the axis/axes involved, or, if Master Gain is available, dial it down to the point where oscillation stops.

Assuming the model does nothing scary that you can't deal with, continue flying to explore the action of the stabilizer. Do a shallow dive to pick up speed and watch for oscillation on one or more axes. If it happens, just throttle back and slow down (oscillation is quite different from control surface flutter and is generally not destructive unless extreme).

Notice how the model handles with the stabilizer turned on. It may be less responsive on one or more axes. Try out your dual/triple-rate settings. Turn stabilization off and on to get familiar with its effects. If you have Master Gain, cautiously explore higher gains.

By the time you've finished the initial flight(s) you should have a good sense of the model's stabilization behaviour and have achieved flyable basic settings on the receiver.

13. Fine tune stabilizer gain

Optimal stabilization occurs when gain on each of the three axes is just below the level where oscillation occurs at the highest normal flying speed. This requires a series of flights to tune the individual gain settings, with repeated landings to adjust the receiver pots, followed by retesting in flight. Many people find that a "quick and dirty" setup, with minimal adjustments to the settings provides adequate stabilization for every day flying, but it's a good idea to experiment a bit.

If you have an 8+ channel transmitter, Master Gain can accelerate the process of optimizing gain. For example, you can, one by one, turn down the gain pots on two axes and experiment with various levels of Master Gain on the third. It's best to aim for a Master Gain setting around 0% (in the middle) for normal flying.

If you don't have Master Gain, here's one possible approach to optimization:

1. Increase the Rudder pot setting by about one to two "hours" (15-30°).
2. Take off with stabilization OFF. Turn ON at a safe height. Watch for oscillation on the yaw axis ("tail wag"). Do a shallow dive to pick up speed and again watch for oscillation.
3. Land and adjust the rudder pot as required. If there was no oscillation, even when diving, turn the pot up another "hour" or so. If there was oscillation, turn the pot down a similar amount.
4. Test and repeat as necessary.
5. Now do the same procedure for the elevator gain pot.
6. Finally do the same procedure to set the aileron gain pot.

Usually, the aileron pot requires the lowest setting (typically below 11 o'clock), with elevator in the mid-range and rudder highest of all. However, the settings can vary considerably with factors such as design, flight speed and control surface setup.

HINT: It's best to do the initial setup and tuning in fairly calm conditions to avoid confusing stabilizer-induced oscillation with buffeting caused by turbulence. Once adjusted, test the effectiveness of stabilization by flying in windier weather, turning stabilization on and off and adjusting Master Gain. You should see a noticeable improvement in smoothness with stabilization turned ON.

14. Restrict Master Gain (if applicable)

Master Gain is very useful to allow for varying wind conditions. But you don't want to accidentally set it to very high gain, which can cause disconcerting oscillation. Hence, once you've set up the receiver pots with the Master Gain knob or slider about the middle, you probably want to limit the maximum available Master Gain.

The simplest way is to use Travel on the Servo Setup menu to limit the throw on channel 8 (Aux3) to, say, 20% on the high side, (numbers -100, 20).

Another way is to use Channel Assign to change channel 8 (Aux3) to control by a switch, then use Digital Switch Setup to set it to, say, -20%/0%/10%. Adjust the values as required to give a suitable choice of three settings. Note that those settings are good for flight but don't allow Master Gain to be used to shut down stabilization. Thus, they thus should probably not be used together with Always-ON.

Using Telemetry

Telemetry is independent of stabilization and can be used with the receiver in stabilized or unstabilized configuration.

The document "Telemetry with the Lemon Rx 7- and 10-Channel Receivers" explains in detail how to setup and calibrate the Telemetry function:
<https://www.rcgroups.com/forums/showatt.php?attachmentid=17692169>

This section just mentions some highlights.

The Lemon Telemetry Receivers send data on receiver voltage, temperature and RSSI (signal strength)³, plus altitude and vertical speed (vario) information from a built-in barometric sensor. Flight battery data can be provided by a voltage sensing wire or the optional V/I (voltage and current) sensor; the latter enables the transmitter to calculate battery capacity-used (mAh). Lemon telemetry is displayed using the existing display screens and, where available, the transmitter's voice capability.

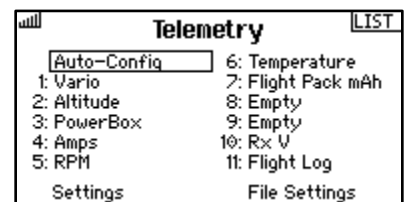

The transmitter can set alarms, in some cases just tones but often voice announcements. For example, an alarm tone and warning can sound when the flight pack voltage drops to a preset value or if the model exceeds a certain height above ground.⁴

To utilize this capability on a telemetry-enabled Spektrum™ transmitter, turn on the radio and power ON the receiver. Go to Telemetry. You will see a display of parameters potentially available from the installed sensors. Run "Auto-Config" if they do not appear.

The Settings item allows selection of either metric or US units.

³ Note that the Lemon RSSI value cannot be directly compared to other signal indicators, such as Spektrum™ or FrSky™ RSSI numbers. Lemon RSSI will read at or close to 100 with the transmitter beside the model and fall as the model moves away. Even at the minimum reading approaching 20, the signal should be adequate for control.

⁴ Users of Spektrum transmitters may occasionally see warning screens relating to such Spektrum-specific parameters as fades, frames or holds. Lemon telemetry receivers do not report these parameters; any such warnings are generally meaningless and can be turned off.

To determine how the various parameters are used by the transmitter, go to any one of the items and double click. You will then see a screen offering several options, which vary from one item to another. Typically, the choices allow maximum and minimum values to be set for purposes of triggering alarms and voice reports to be made at regular intervals or when a switch is flipped. Note that not all the parameters displayed on the Telemetry screen will turn out on inspection to be functional and useful.

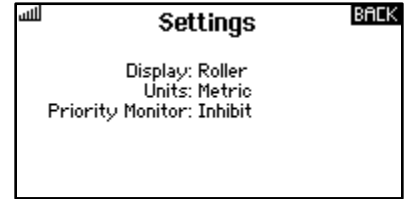

Examples of the options available are shown in the pictures below.

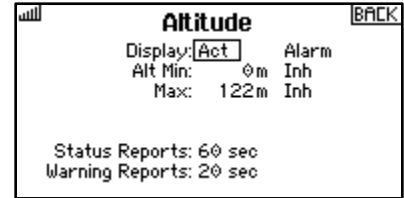
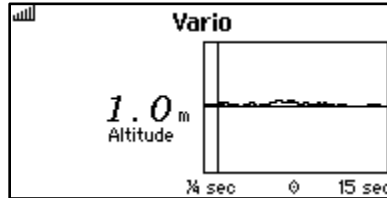
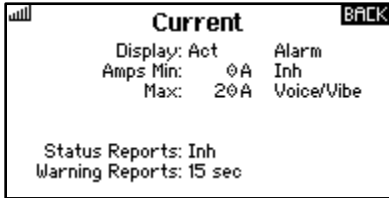

On the main screen of the transmitter, you can scroll through the available telemetry screens using the roller.

The transmitter can record the telemetry data on the SD card for later review, a potentially very valuable feature in the event of problems. This is set up using the File Settings item on the Telemetry screen.

To recalibrate the receiver's telemetry to specific voltage and/or current sensors, use screens 14 and/or 15 in the Advanced Screens, and follow the instructions in the document "Telemetry with the Lemon RX 7 and 10 Channel Receivers": <https://www.rcgroups.com/forums/showatt.php?attachmentid=17692169>.

The procedure described there assumes use of buttons, but Text Display makes things easier.

Factory Reset the Receiver

A reset will cancel all programming and other settings, leaving the receiver in simple, unstabilized status. The transmitter is not required for this operation.

1. With the receiver ON, press and hold Button B and Button F simultaneously for about 6 seconds.
2. Release the buttons when all receiver LEDs flash.
3. Press Button C briefly. The receiver will flash for about 1 second, then reboot.
4. Reset complete. No lights showing.

Note that Reset does not clear an existing bind.

You can also reset the receiver using the transmitter and Text Display (see page 7).

Appendices

Appendix 1: Setting Up Text Display with EdgeTX

On a colour screen radio such as the Radiomaster TX16S, bind as usual then press the SYS button. Choose the TOOLS icon (Wrench and Screwdriver), then select “DSM Smart RX Telemetry”. On the screen that appears, scroll down to TextGen and select it. The LEMON RX screen will then display.

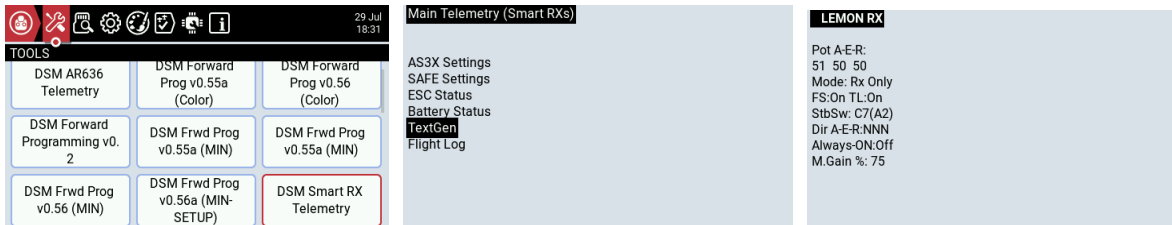

With a black and white screen EdgeTX radio the required script file must be downloaded from GitHub and copied to the SD card. Go to https://github.com/frankiearzu/DSMTools/blob/main/DSM_Telemetry

Find the latest version of the DSM_Telemetry zip file, download (using the download button) and extract all files. Copy the file DSM_SmartRX_Tel.lua to the SD card folder SCRIPTS/TOOLS. In Radio Setup select this file.

Edge TX transmitters from version 2.8.3 onwards have DSM Telemetry scripts installed or available that enable TextGen and thus support Lemon Text Display.

Appendix 2: Meaning of the LM0086 Receiver LEDs

LED Identification

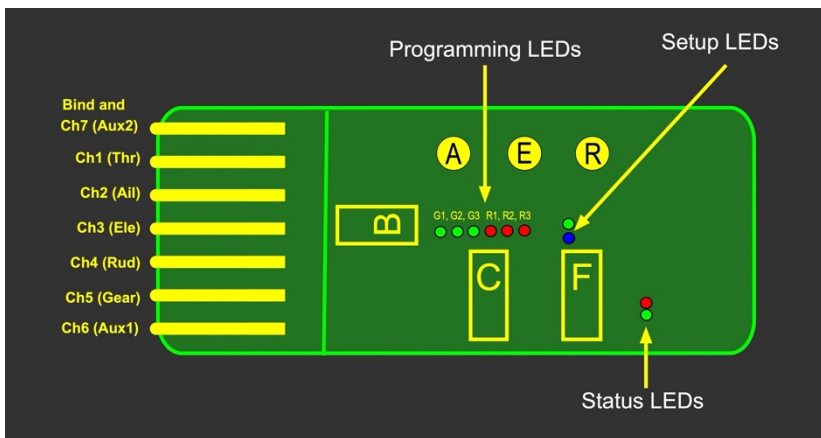

This diagram identifies the various indicator LEDs on the receiver.

With the receiver powered ON, locate the three green and three red programming lights (G1, G2, G3 and R1, R2, R3). Press button C for no more than 2 seconds to identify these lights.

Also locate the position of the blue and green Setup lights and the red and green Status lights, as shown in the picture.

Red Stabilization Option LEDs

The three red LEDs shown above are referred, from left to right, as R1, R2, R3. They indicate the stabilization mode of the receiver as follows.

- Option A: Delta Wing (Elevons) – R1
- Option B: V-Tail – R2
- Option C: Normal Tail – R1+R2
- Option D: Dual Aileron Channels with normal tail – R1+R2+R3
- Option E: Dual Aileron Channels with V-Tail – R2+R3

The option is chosen using Text Display. Dual Aileron Channel is set separately from the basic option.

Note that either R1 or R2 or both must be ON for stabilization to be active. Thus, setting R3 without either Option B or Option C will have no effect. Settings are retained even when power is removed.

Once a stabilized option is set, stabilization can be turned on and off in flight by a switch on the transmitter. When stabilization is ON, the green Status LED will be illuminated.

Green Stabilization Direction LEDs

The three green LEDs next to the red mode LEDs indicate whether stabilization direction of each of the control channels (A, E, R) is Normal (OFF) or Reversed (ON). The definition of normal and reversed is purely arbitrary and stabilization direction on each axis MUST be determined by physical testing. Direction is changed using Text Display. See item 7 on page 9.

Stabilization ON/OFF

By default, Stabilization ON/OFF is controlled by a switch assigned to CH7 (Aux2). This can be changed in Text Display to CH5 (Gear). Whether stabilization is ON or OFF is indicated by the green Status LED beside the red receiver Status LED.

User-set Failsafe LED

A green Setup LED indicates that User-set Failsafe is active. This can be cancelled in Text Display.

Appendix 3: Understanding Throttle Lock

Note that TL in the Text Display screens refers to "Throttle Lock", not telemetry. It is a function that alters User-Set Failsafe behaviour.

How User-Set Failsafe works

User-Set Failsafe kicks in if the receiver loses transmitter signal for approximately one second.

If TL is ON, then when signal loss is detected a series of Throttle OFF commands (-100% pulses) is sent for the first 0.1 seconds, after which all channels go to logic low. The effect of this is to force the ESC instantly to zero and keep it there by stopping servo pulses. The reason for the brief initial -100% command is that a few ESCs will run the motor briefly when signal is lost if the last known throttle channel value is not -100%. For failsafe the motor should ideally stop instantly, and the control surfaces should stay where they were when signal was lost. Meanwhile the receiver looks for a valid signal; if found, full control is restored. If not, after 2 seconds, the receiver outputs the user-set channel values to all the connected servos/ESC indefinitely until a radio signal is found.

If TL is OFF, then if signal loss is detected all channels go to logic low, meaning no servo pulses are sent. Normally, the ESC detects the loss of control pulses and stops the motor and the control surfaces will stay where they were when signal was lost. Meanwhile the receiver looks for a valid signal; if found, full control is restored. If not, after 2 seconds, the receiver outputs the user-set channel values to all the connected servos/ESC indefinitely until a radio signal is found.

If User-Set Failsafe is not set, then the receiver will in all cases output no pulses until the signal is restored.

Why is Throttle Lock an option?

TL is set to ON by default. When User-Set Failsafe kicks in, Channel 1 is instantly changed to -100% (low throttle) and then to no pulse. After 2 seconds all channels move to the user-set fail-safe positions. For most people flying Spektrum channel-order electric planes, this is the desired behaviour.

Some fliers, however, notably glider pilots, use Channel 1 for a different purpose such as a flight control surface; having the control move briefly to -100% on failsafe is an issue — sometimes an alarming one! Also, TL should not be used with models that have an IC engine. Hence the option to have the TL OFF.

Appendix 4: Troubleshooting Text Display

Problem 1: The Text Display screen does not appear after the other telemetry screens

Your receiver may not support Text Display.

Text Display was announced in August 2024 and a new label was introduced to distinguish the receivers with this capability; it has larger print and does not have fine print showing the receiver LEDs. See page 5.

However, certain production receivers had the new firmware before that. Thus, a telemetry receiver from this period with the old label may or may not have Text Display capability. To find out whether you have one of these, just try it out.

Binding with automatic telemetry recognition on a Spektrum transmitter may have failed.

If the Telemetry Autoconfigure does not find the Lemon screen, then try this:

1. On a DX or NX transmitter, with the receiver powered-up, from the main screen click the roller to get “Function List” and scroll to “Telemetry.” On an iX radio, select “Telemetry” on the main screen.
2. Click on “Telemetry”, then scroll to an “Empty” item and select it. When it is flashing, scroll through the options and select “TextGen”. Make sure it is “Act” (Active) not “Inh” (Inhibited). Go back to the main screen and scroll to the right until you come to the “Lemon RX” telemetry page.

Problem 2: Setup Mode does not work

With some early versions of the Text Display firmware, basic text information may be displayed but Setup Mode will not be available. In receivers with full Text Display capability, whether using a Spektrum or an EdgeTX transmitter, the default model values will work in nearly all cases.

Don't forget that Setup Mode is only available for about the first 60 seconds after power-up. So try restarting the receiver. If that doesn't enable Setup Mode in response to the “Show Config.” Option, then:

Your Lemon receiver may not support Setup Mode.

Lemon Gen2 Telemetry Receivers produced between April and August 2024 may or may not have Setup Mode, even if they enable Test Display basic screens. Those produced after this do have Setup Mode, but retailers may have had older stock.

Your transmitter may not support Setup Mode.

Spektrum Gen2 DX transmitters should have Airware 2.09 or higher for optimum TextGen performance. EdgeTX transmitters should have at least v.2.8.3 firmware. B&W transmitters using EdgeTX require the DSM Telemetry LUA file to be installed (see Appendix 1).

OpenTX and ERSkyTX do not support the necessary TextGen function at this time.

Stabilization is active.

Ensure stabilization set to OFF (red Status LED only).

Your channel outputs may not be correct.

Check that the channel monitor on your transmitter shows plus or minus 100% output on each of channels 1-4 with sticks fully deflected in the outside lower corners of the gimbals. Check the following:

- Dual Rates are active at less than 100%. This is the most common cause of problems.
- Servo Output (Travel) is not at 100%. Temporarily set all four channels to 100%.
- Throttle kill/lock may be forcing the throttle channel to a value other than -100%.
- You have a 3-channel model with no output on channel 2 or 4.
- You have a glider with no output on the motor channel.