

---

---

**TOYAN** *ENGINE*

FS-L400BGC

---

---

## OPERATING MANUAL

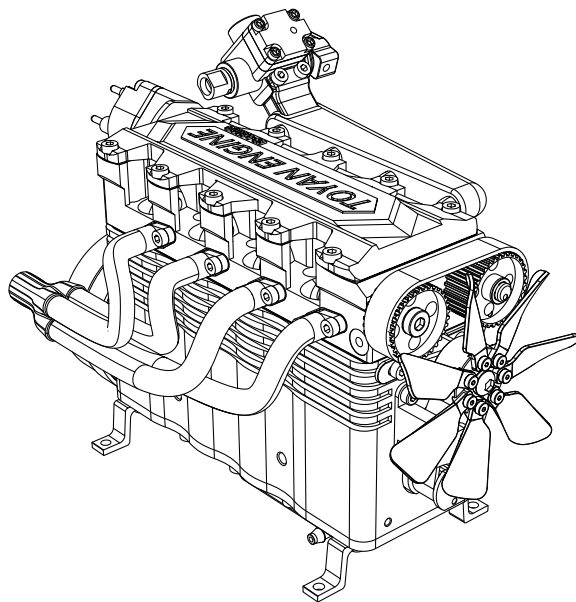

Thank you for Choosing our products,Model FS-L400BGC is one accessories kit with Precise Four Cylinder Four-stroke model engine,. Before assembling and operating your engine, please read the "safety instructions and warnings" section on pages 2-3 of this booklet and contents of accessories assemblyl,to strictly adhere to the advice contained therein

>Also,Please study the entire contents of this instruction manual,so as to familiarize yourself with engine controls and other functions.

>Furthermore,Keep these instructions in a safe place so that you may readily refer to them whenever Necessary

---

# CATALOGUE

SAFETY INSTRUCTIONS AND WARNINGS	02 ~ 03
INDUCTION	04 ~ 11
ASSEMBLY OF COMPENTS	12 ~ 46
ATTENTION ABOUT STARTING	47 ~ 49
OPERATION AND ADJUSTMENT	50 ~ 53
CARE AND MAINTENANCE	54 ~ 55
REPLACEMENT OF ACCESSORIES	55
BUG CHECKING	56
ENGINE THREE VIEW DRAWINGS	57 ~ 58
EXPLODED VIEWS	59
COMMITMENT	60
BOM LIST	61 ~ 62

## SAFETY INSTRUCTIONS AND WARNINGS

Remember that your engine is not a "toy", but a high-efficiency internal combustion engine, the output power may cause you harm, or other effects, do not change or disassemble

As a professional user, please make sure the engine runs safely and carefully.

If at some future date, your Toyan engine is acquired by another person, we would respectfully request that these instructions are also passed on to its new owner.

- The advice which follows for all production engines ,Incorrect operation or Ignore safety can lead to engine damage or danger

**Warning: These cover events which might involve serious (in extreme circumstances, even fatal )injury.**

● Model engine fuel is poisonous. Do not allow it to come into contact with the eyes or mouth.

Always store it in a clearly marked container and out of the reach of children.

● Model engine fuel is also highly flammable. Keep it away from an open flame, excessive heat, sources of sparks, or anything else which might ignite it. Do not smoke or allow anyone else to smoke, near to it.

● Never operate your engine in an enclosed space. Model engines, like automobile engines, exhaust deadly carbon-monoxide. Run your engine only in an open area.

● Model engines generate considerable heat. Do not touch any part of your engine until it has cooled. Contact with the muffler,cylinder head or exhaust header pipe, in particular, may result in a serious burn.



- This engine was designed for science experiments, model demonstrations, model car drives. Do not attempt to use it for any other purpose.
- Mount the engine in your model securely, following the manufacturers' recommendations, using appropriate screws and locknuts.
- Noise will happen when starts, please buy our matching muffler exhaust pipe or run away from the living environment, because the noise of the operation may irritate others.
- Safety glasses are strongly recommended.
- Please note that the electric plug or battery wire should not touch the rotating parts. Also check whether the connection of the throttle rocker arm is firm.
- To be safe, keep all spectators (especially children) at least 3 meters away from engine when start the engine.
- If you want to stop engine, shut off the throttle completely. In an emergency, clamp the fuel line in front of the carburetor to cut off the fuel supply
- Do not attempt to remove the flywheel and start the synchronous pulley
- Do not extend the starting battery wire by more than 20cm. Otherwise, the starting current will be insufficient due to the resistance voltage drop inside the battery line
- When starting the engine, please do not press the start button for a long time. The maximum starting time is 5 seconds. If it does not start, please stop for 15 seconds and press the button to start again, so as not to burn the starting motor and ignition circuit due to the long starting

# INTRODUCTION

## engine structure and components

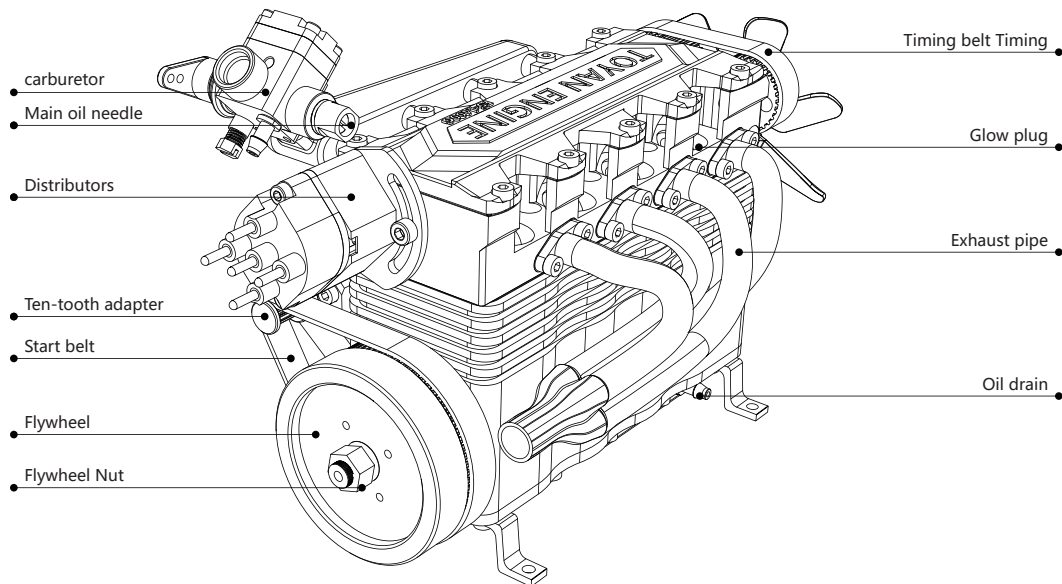

## engine structure and components

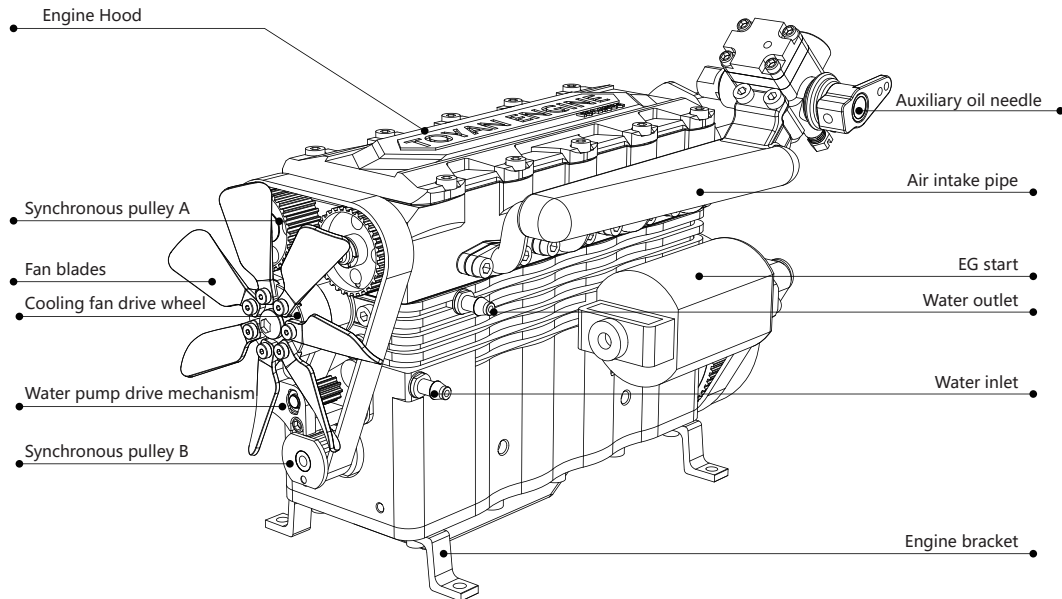

Distribution diagram of parts packaging

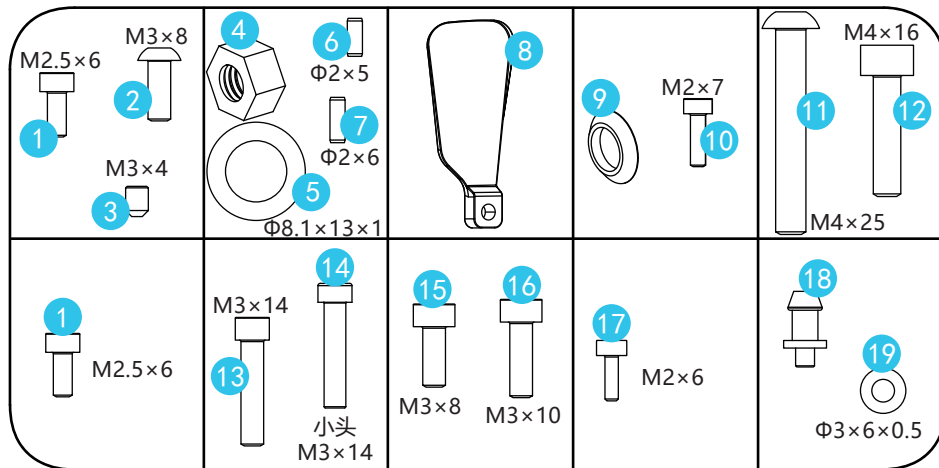

Distribution diagram of parts packaging

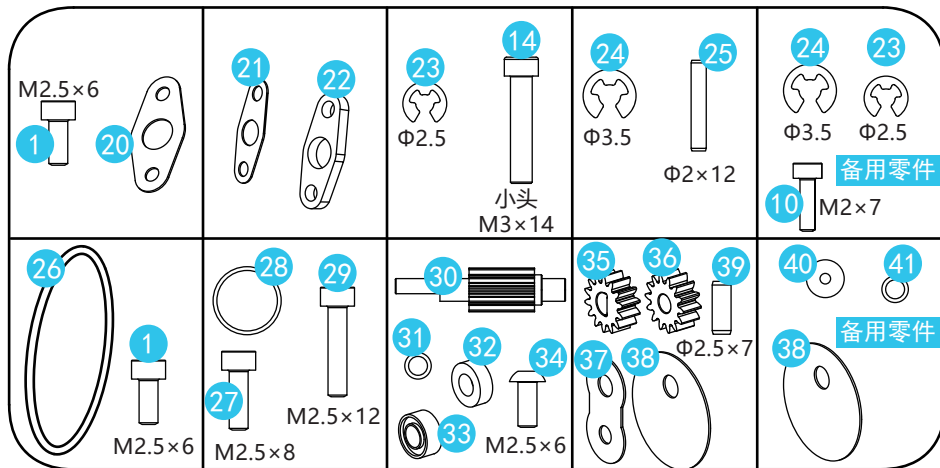

### Distribution diagram of parts packaging

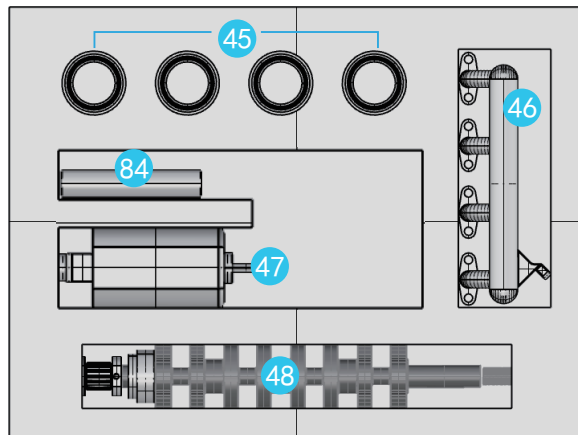
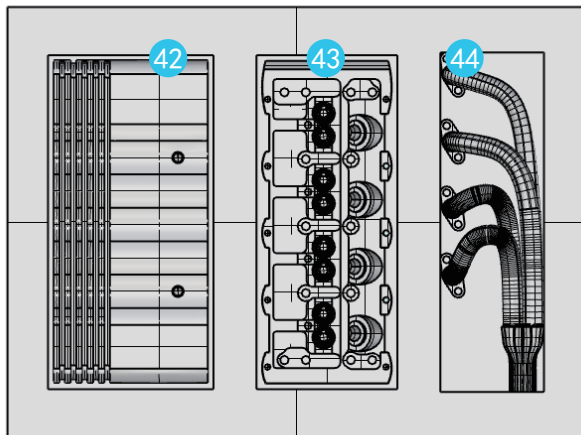

Distribution diagram of parts packaging

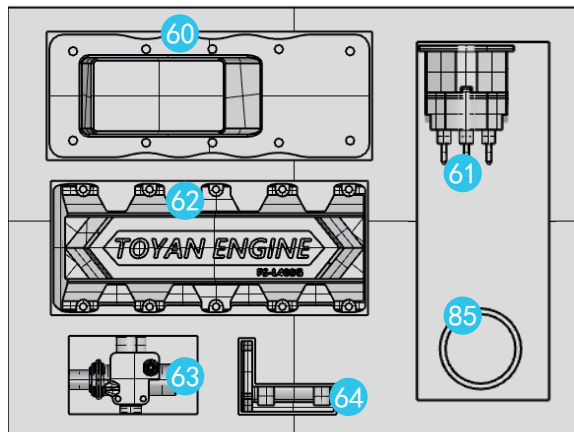
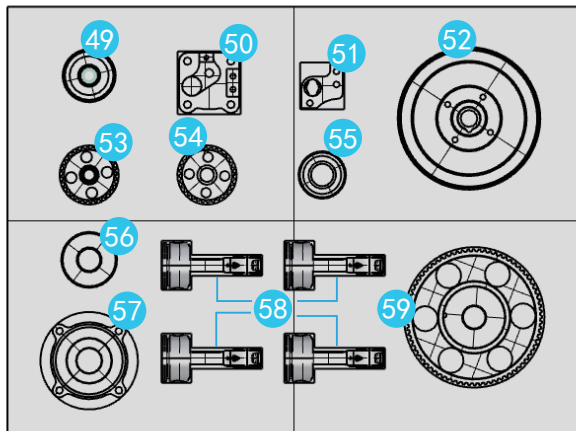

Distribution diagram of parts packaging

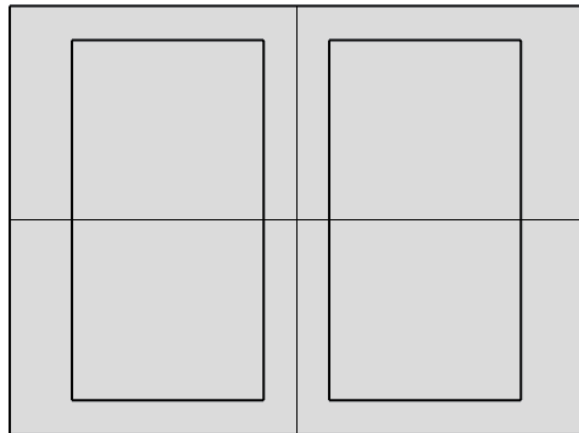
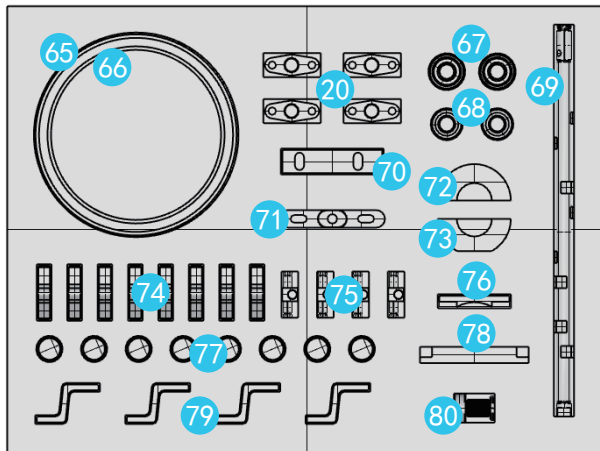



## Distribution diagram of parts packaging

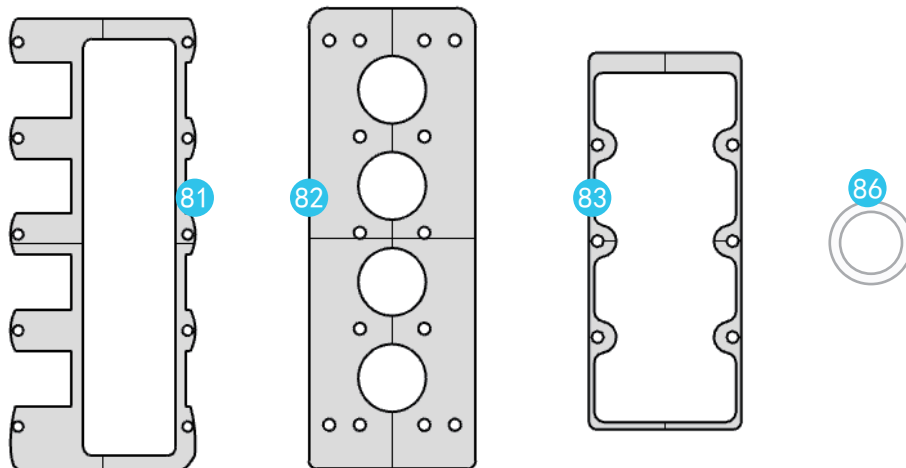

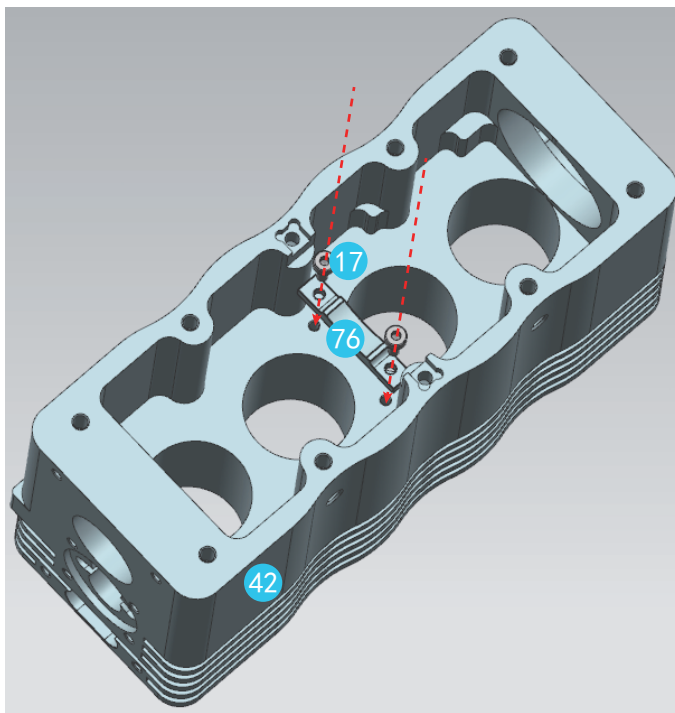

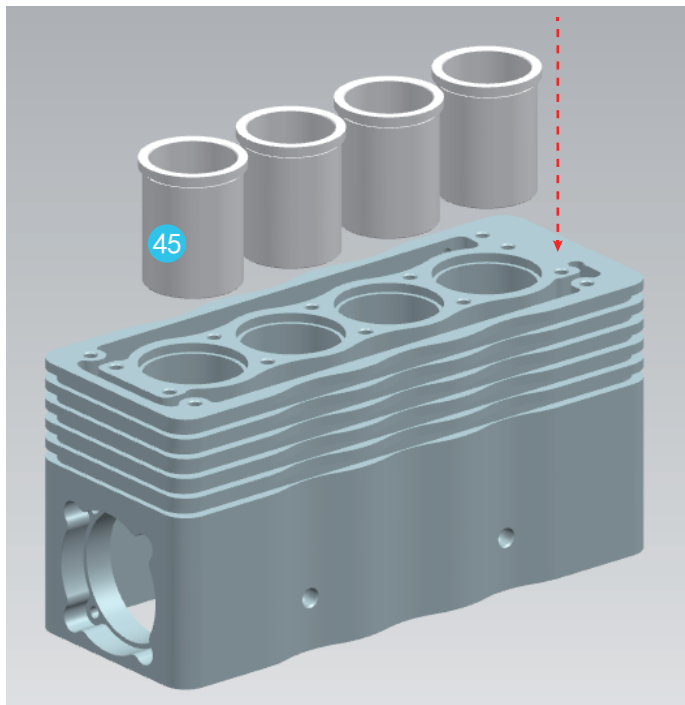

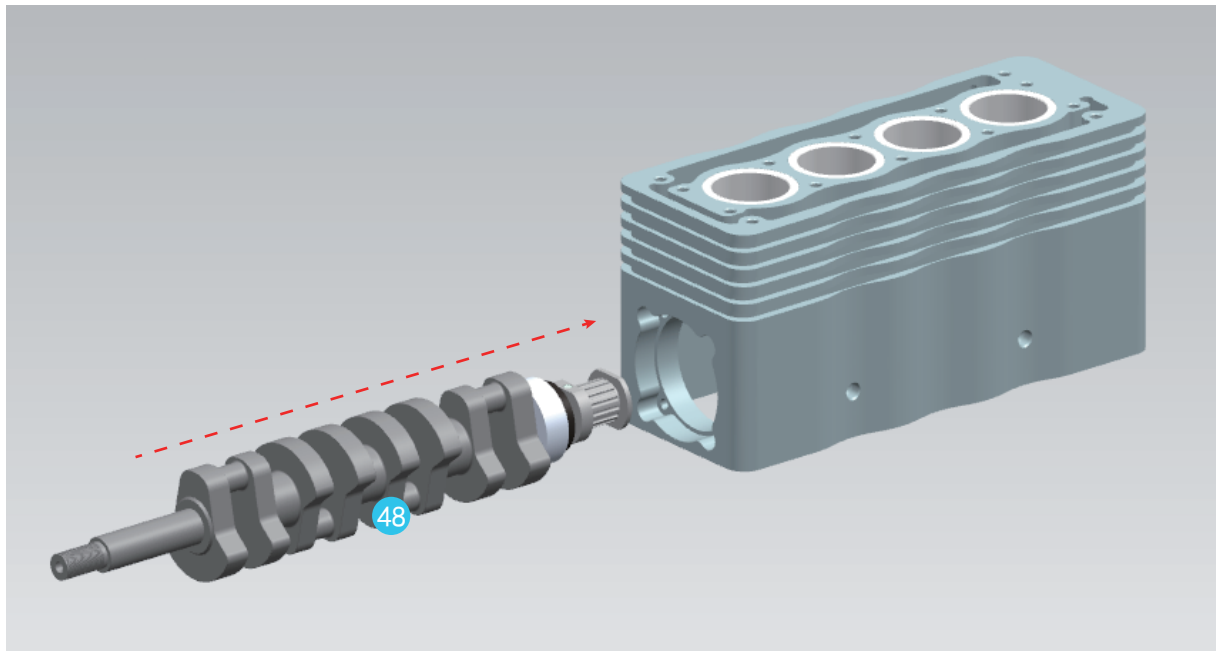

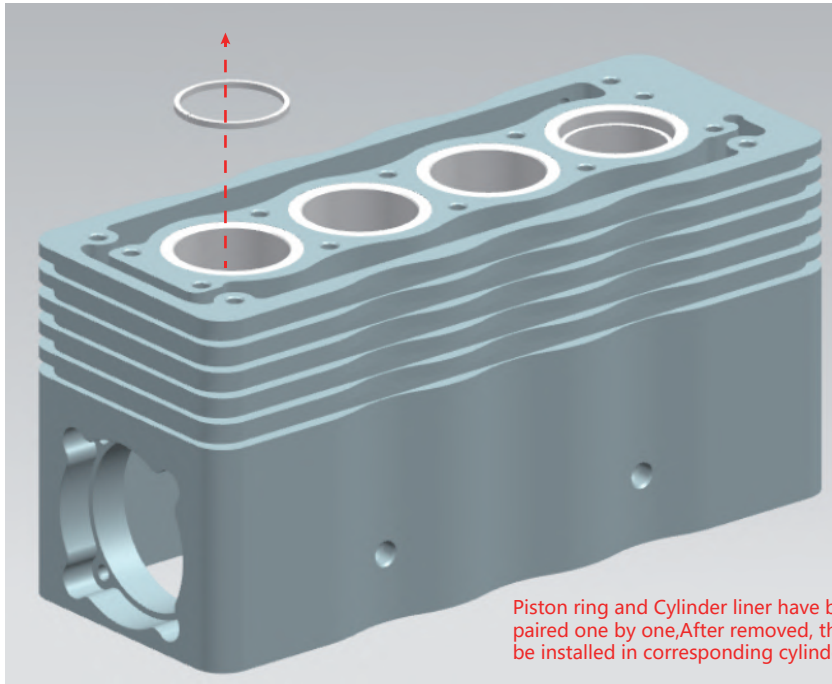

Piston ring and Cylinder liner have been paired one by one, After removed, they shall be installed in corresponding cylinder liner

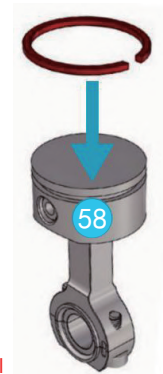

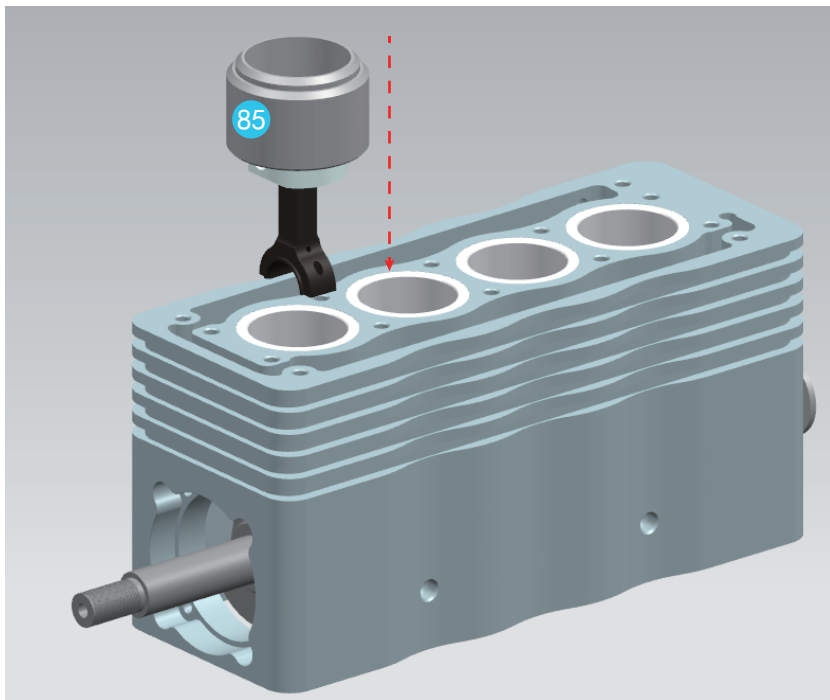

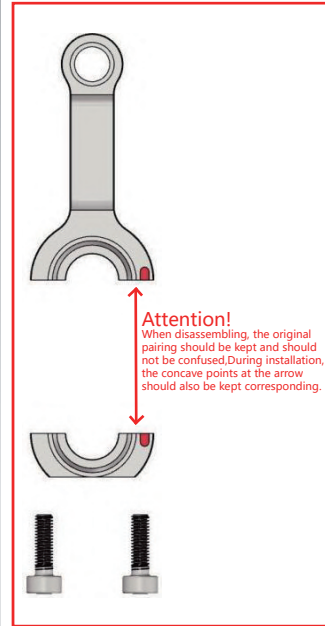
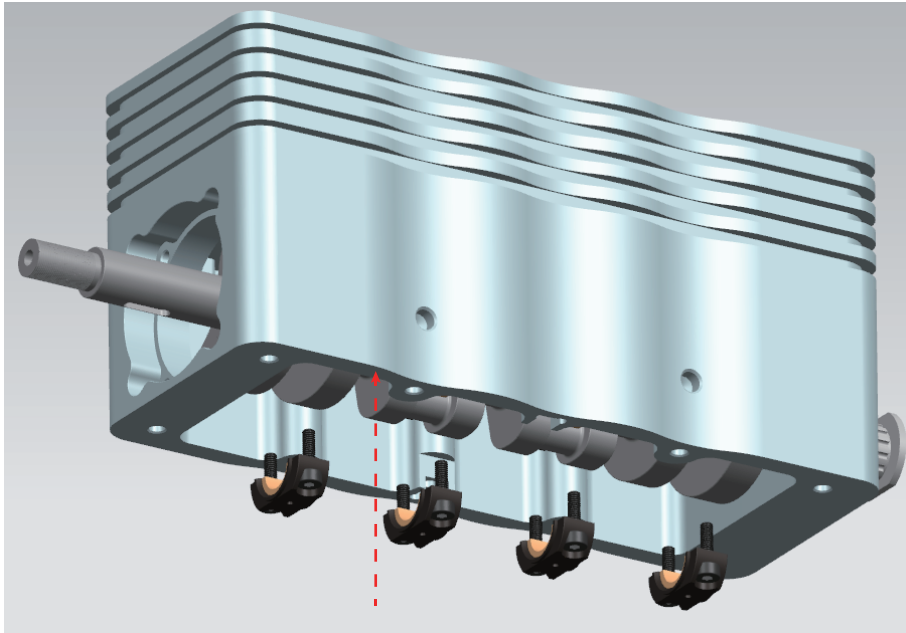

## Finished diagram

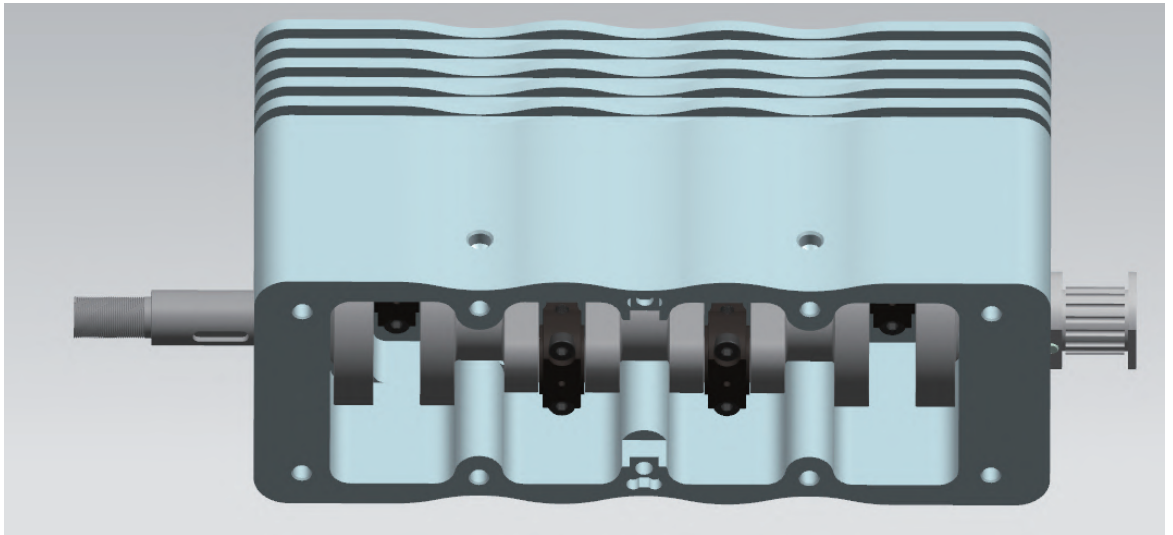



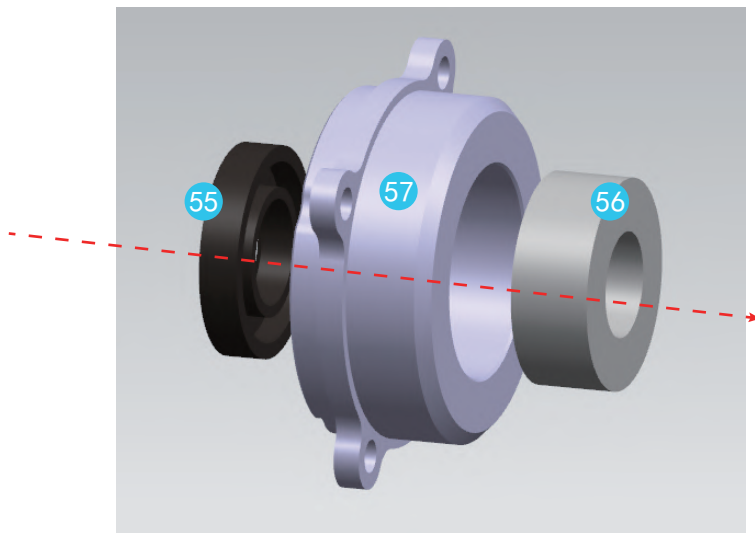

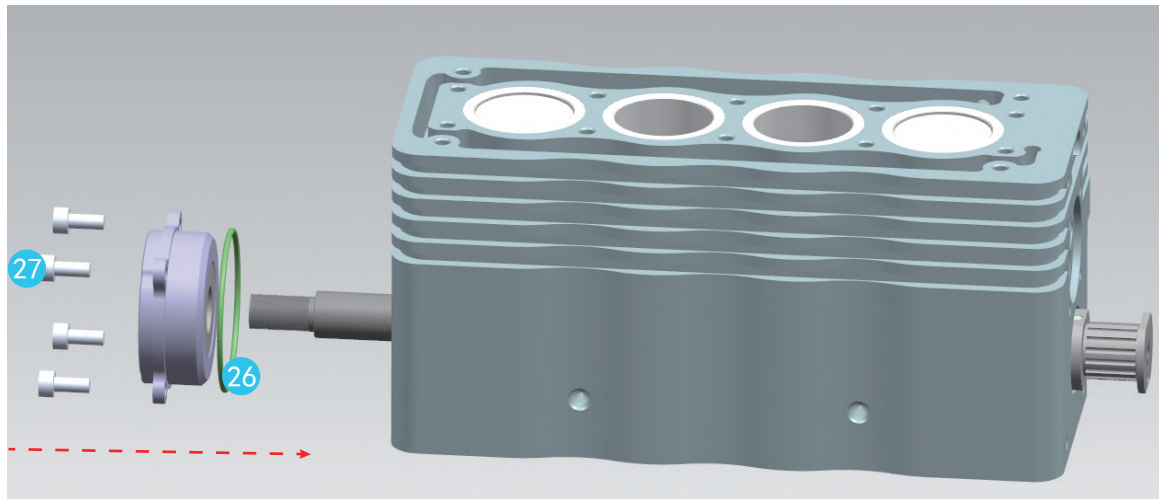

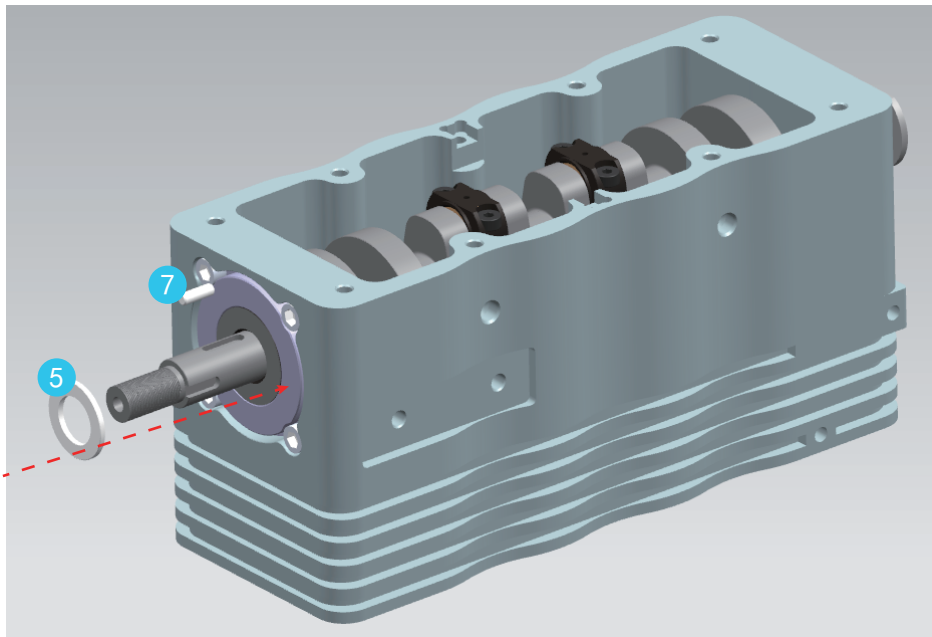

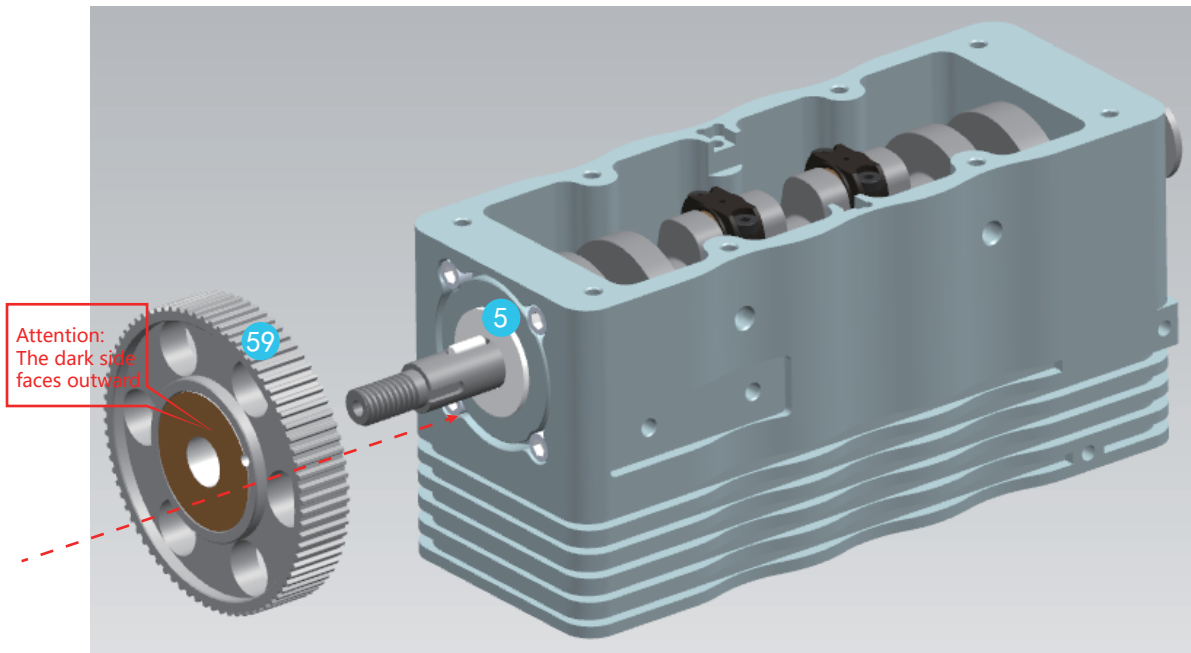

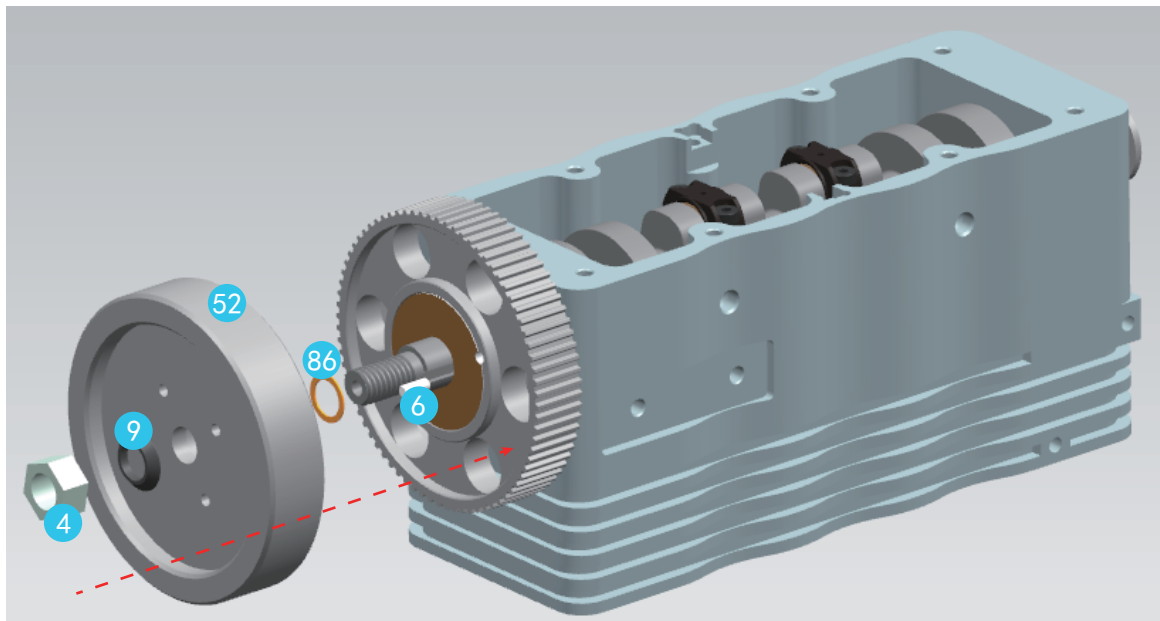

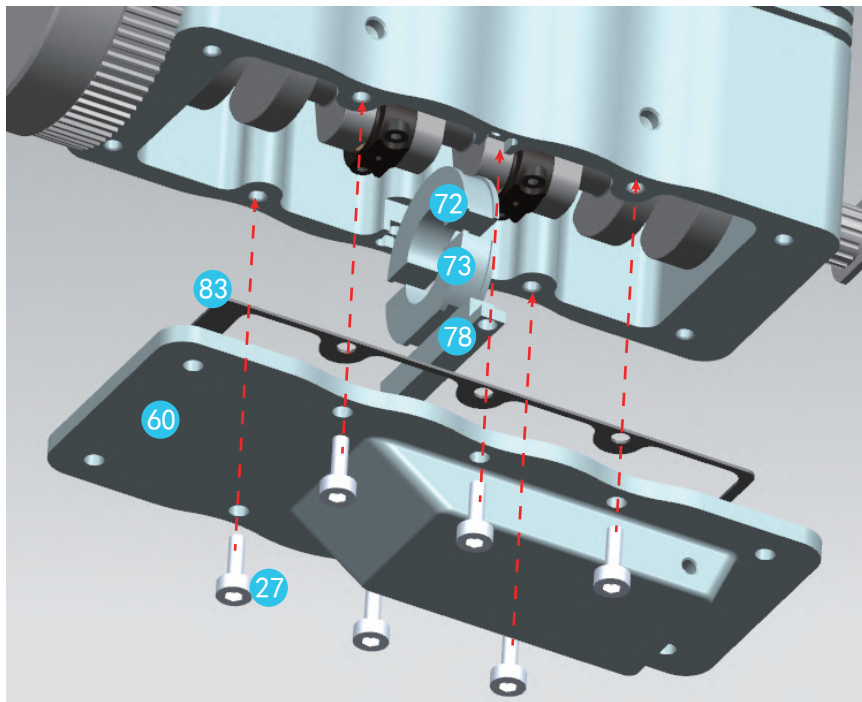

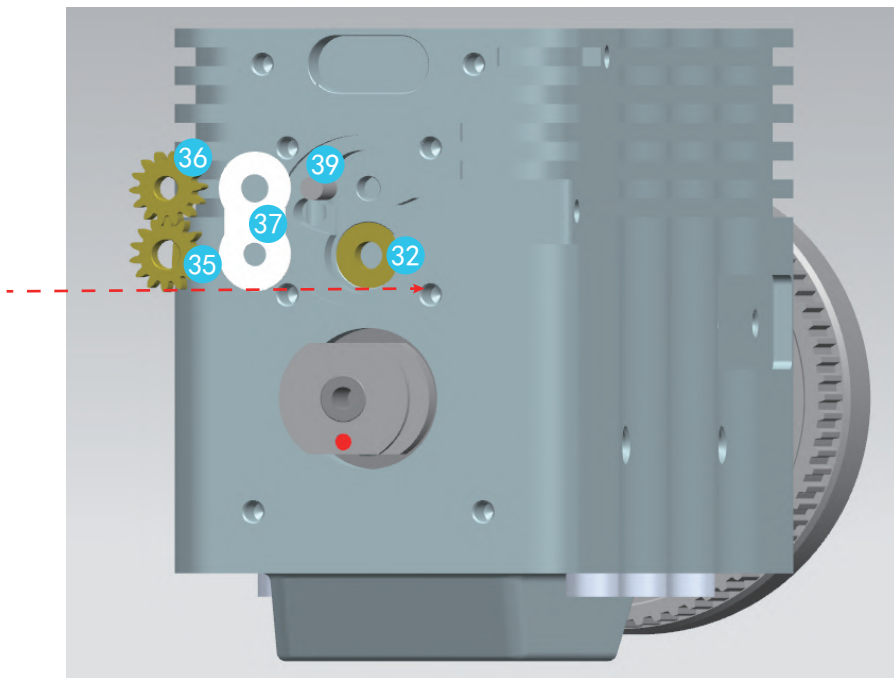

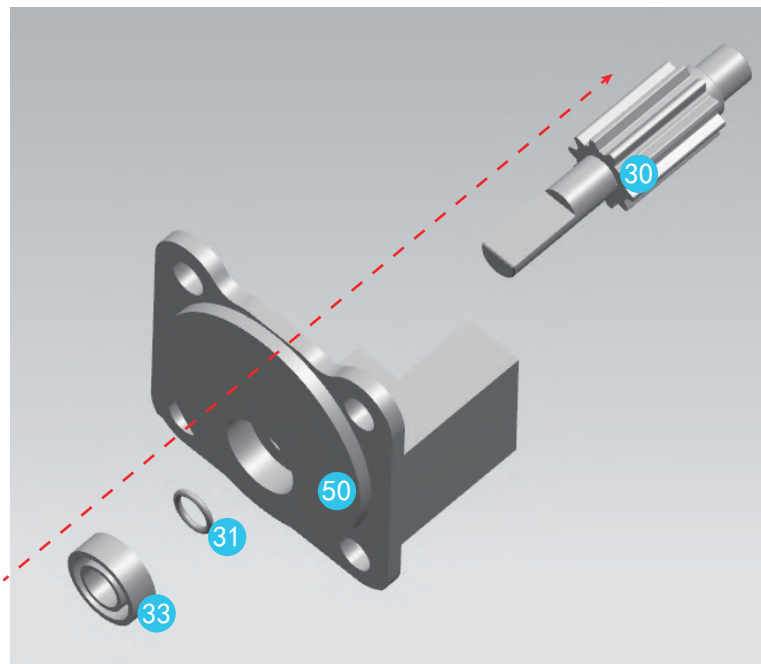



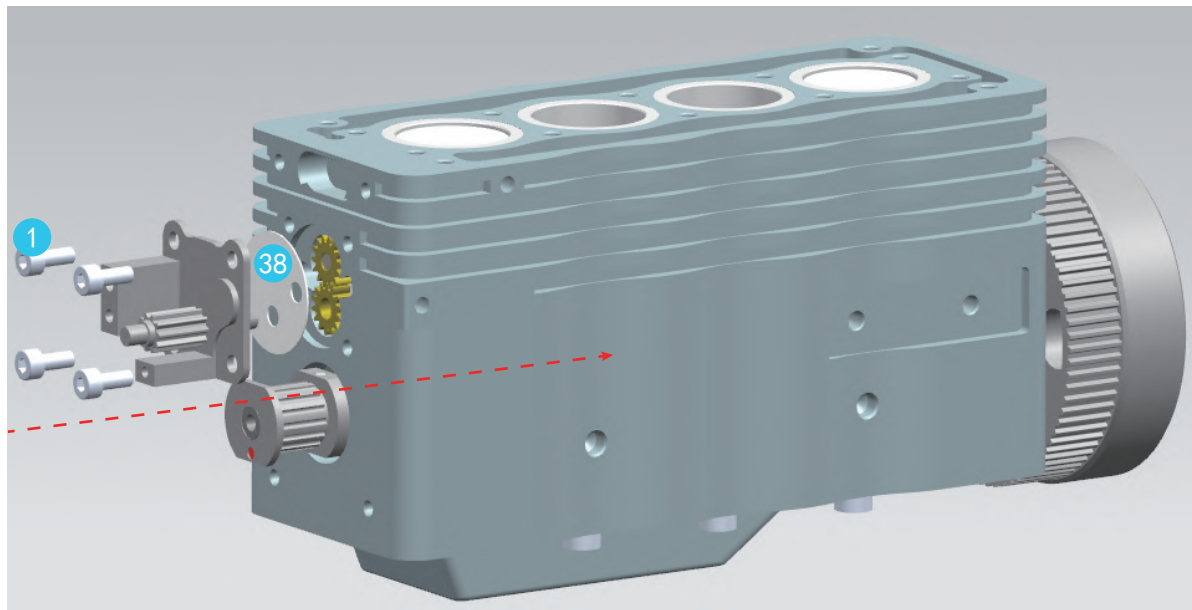

The black screws are numbered 13

The white callout screws are numbered 14

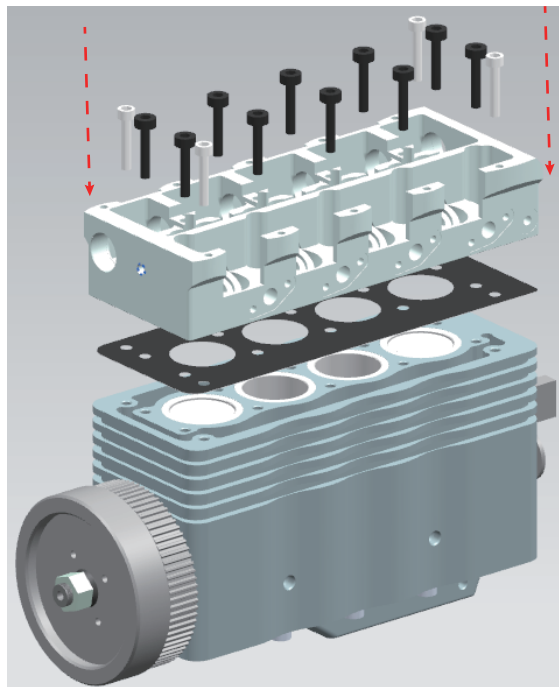

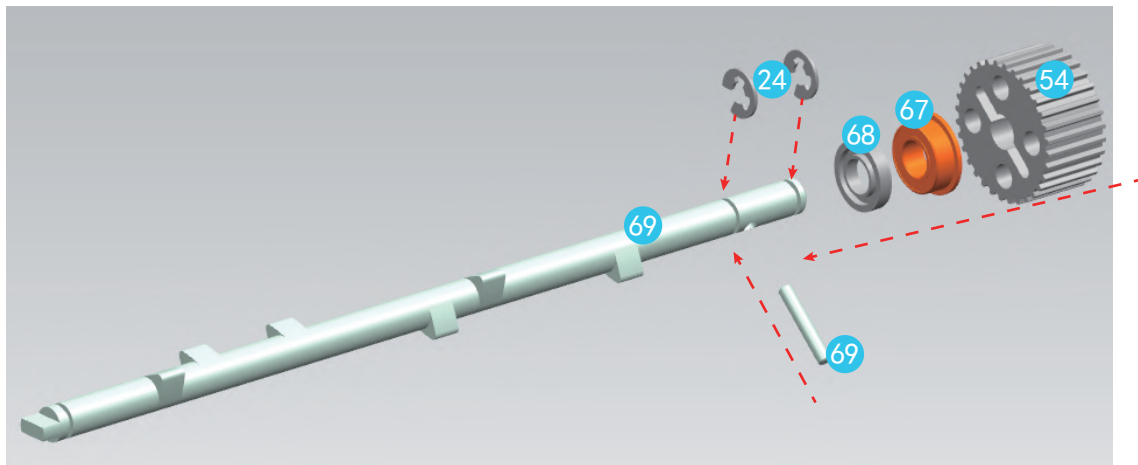

## No. 84 is an auxiliary tool

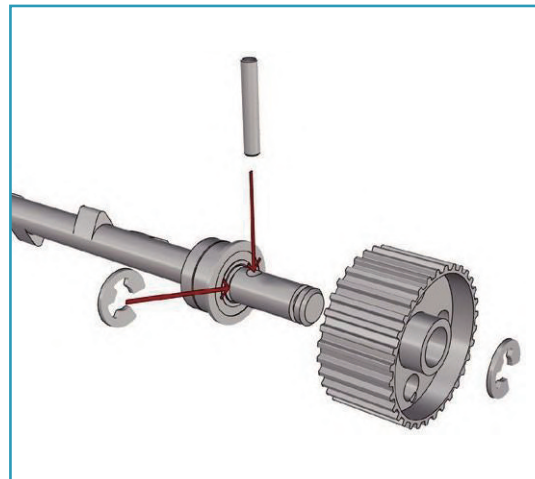
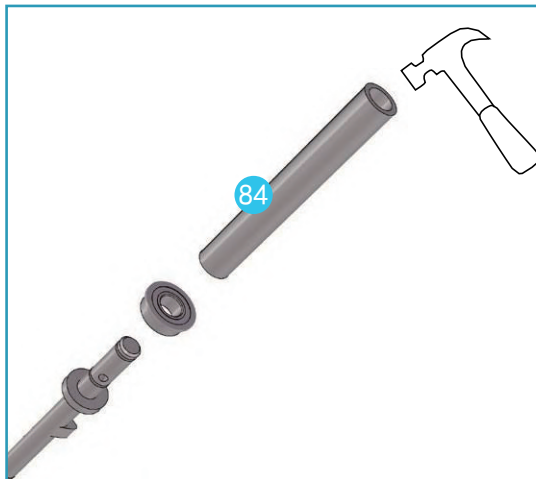

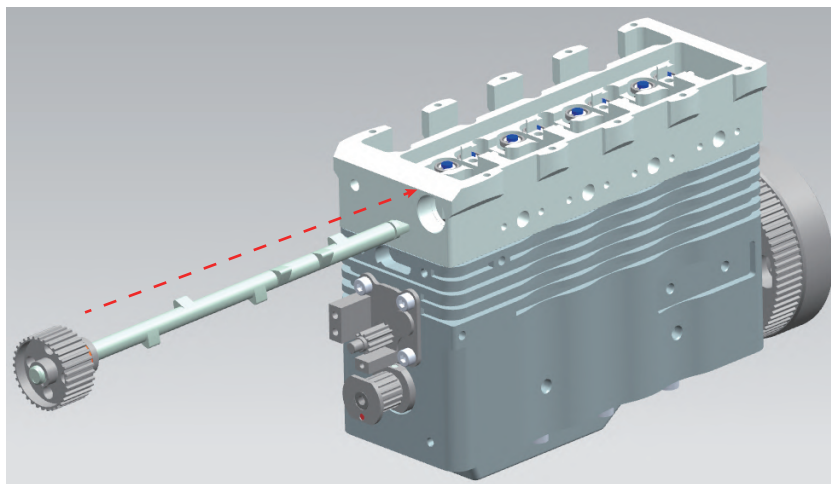
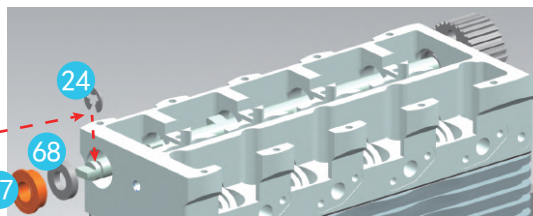

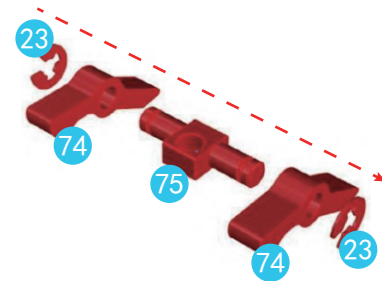
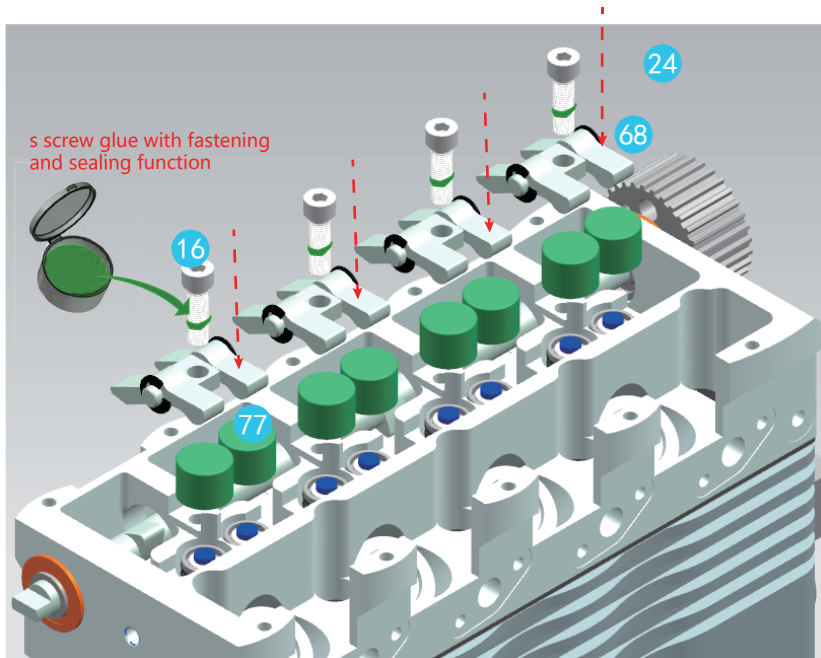

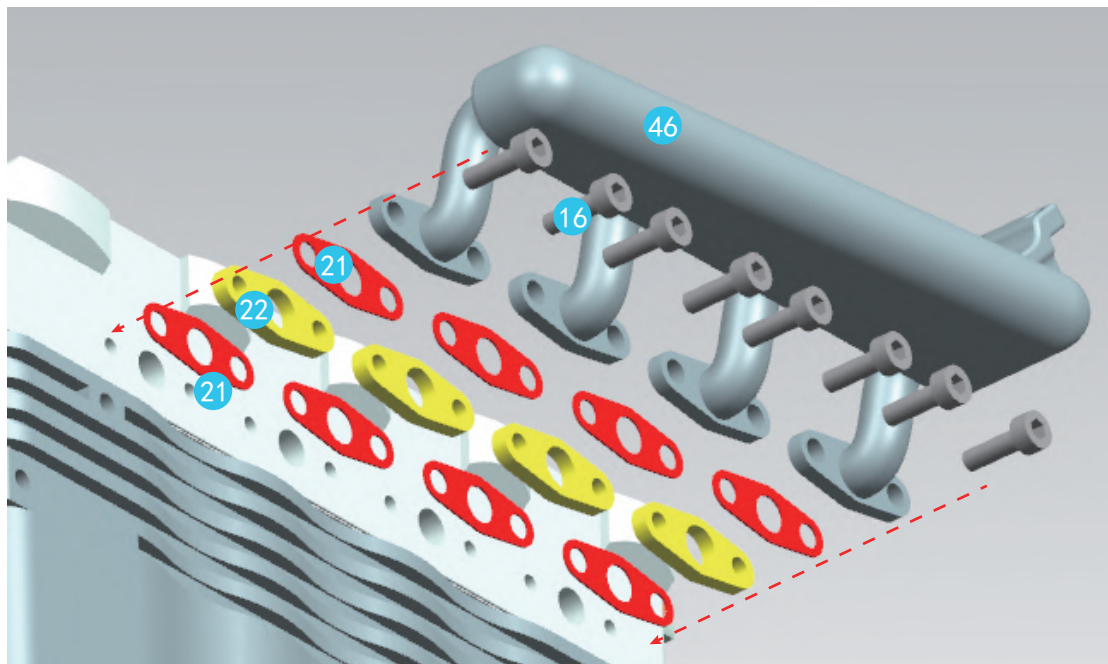

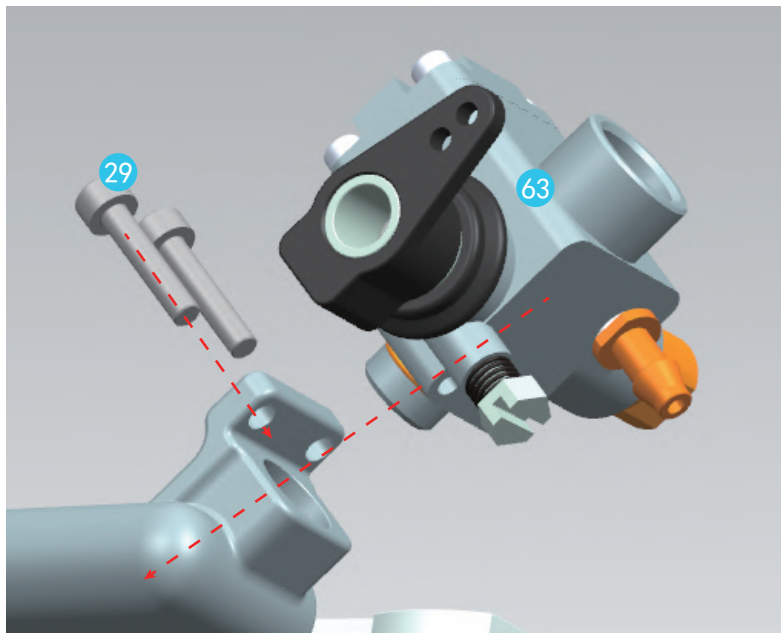



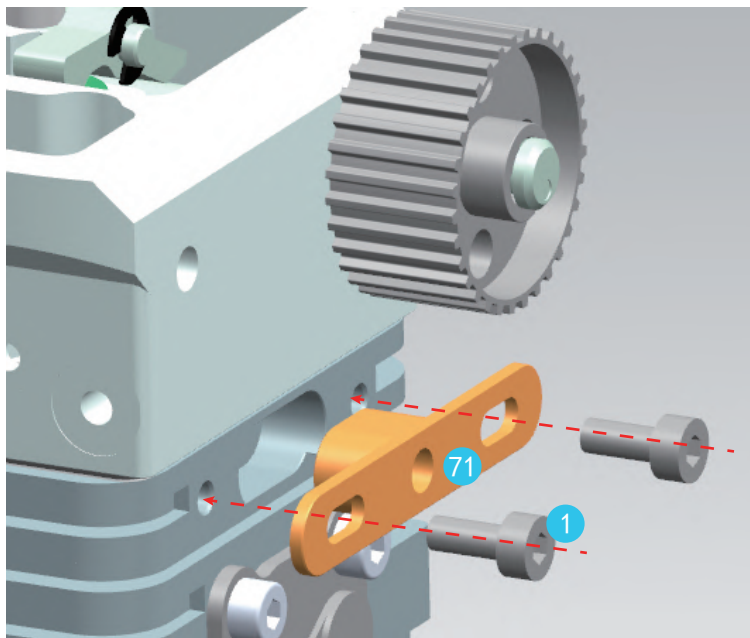

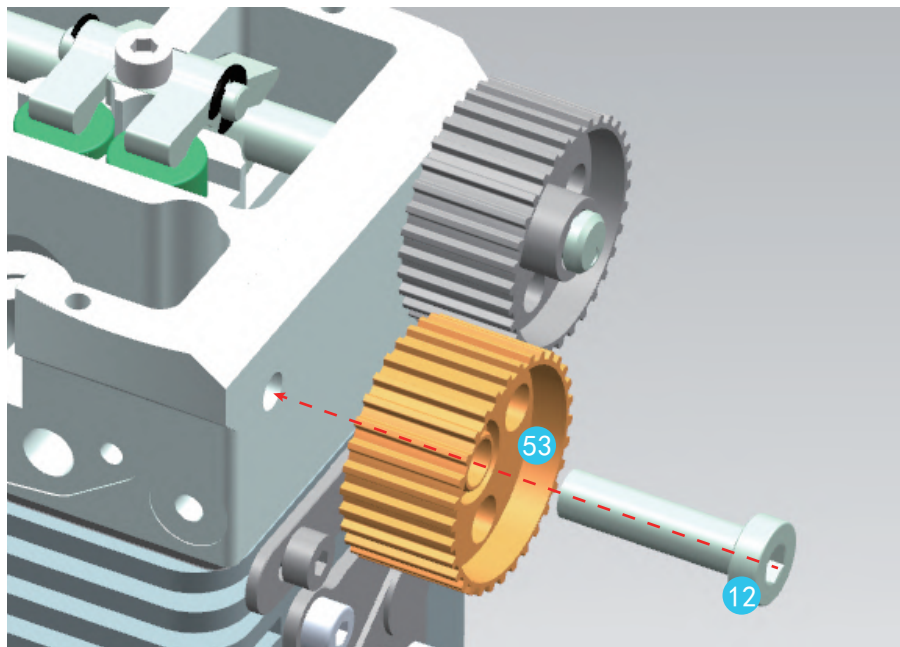

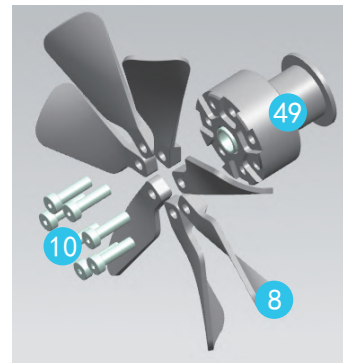
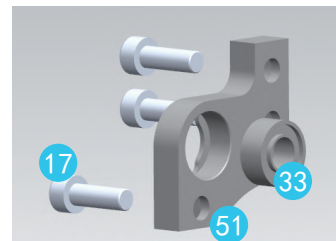
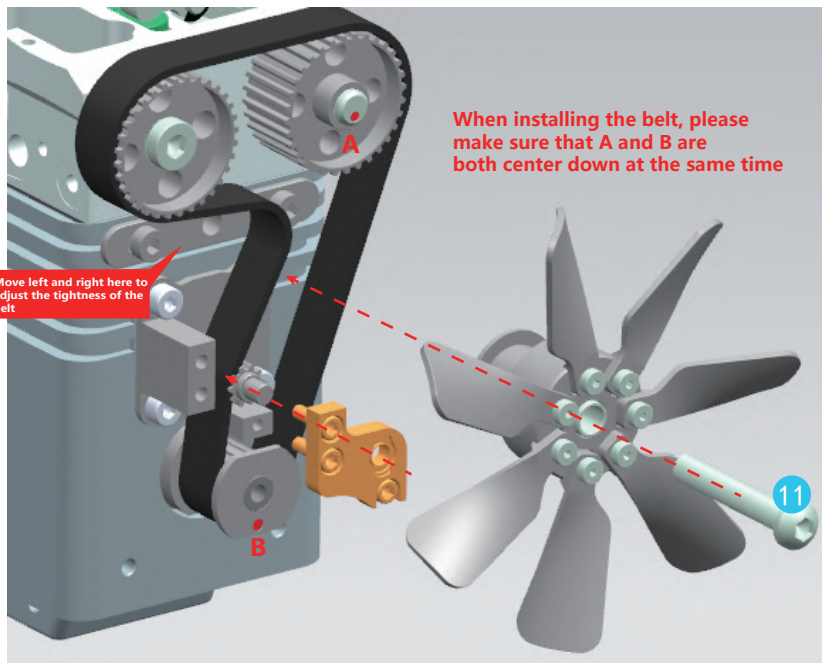

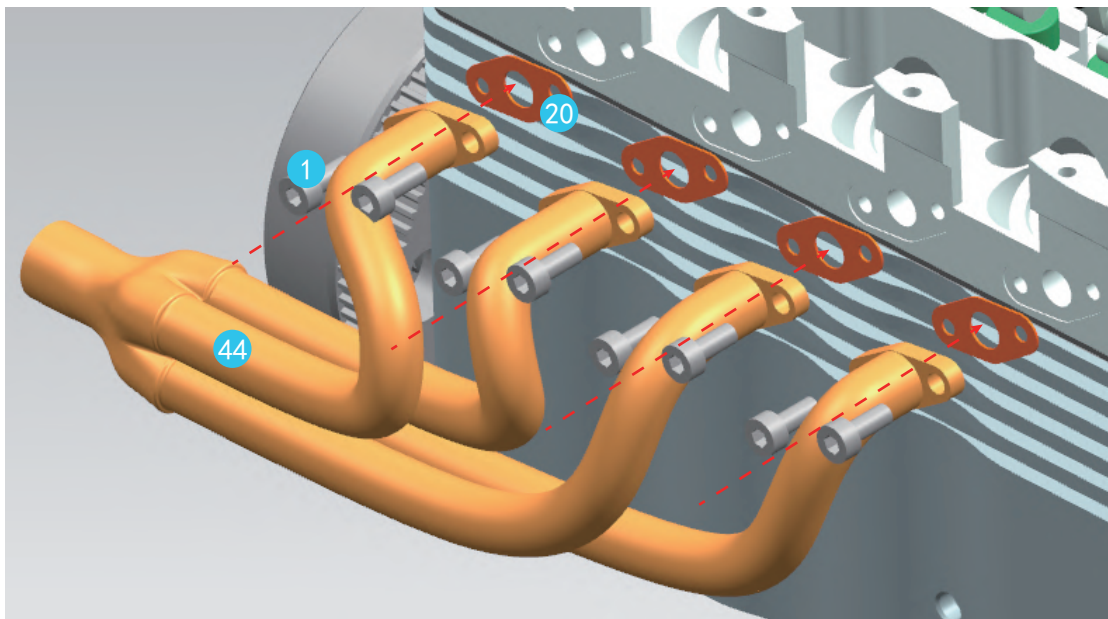

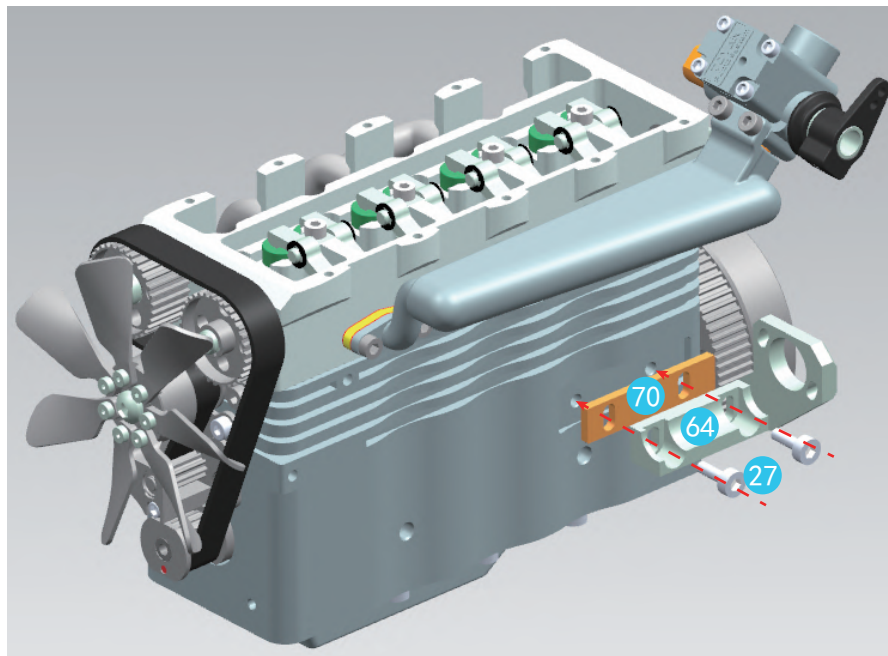

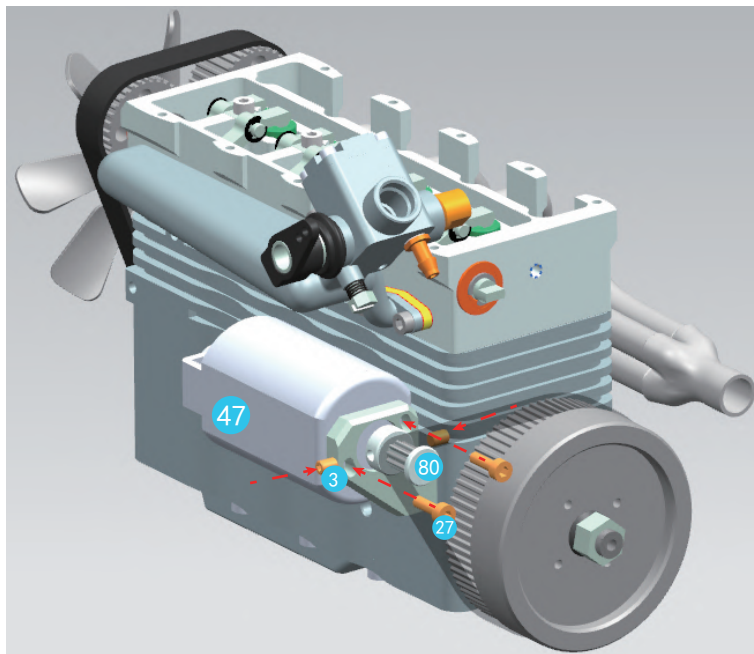

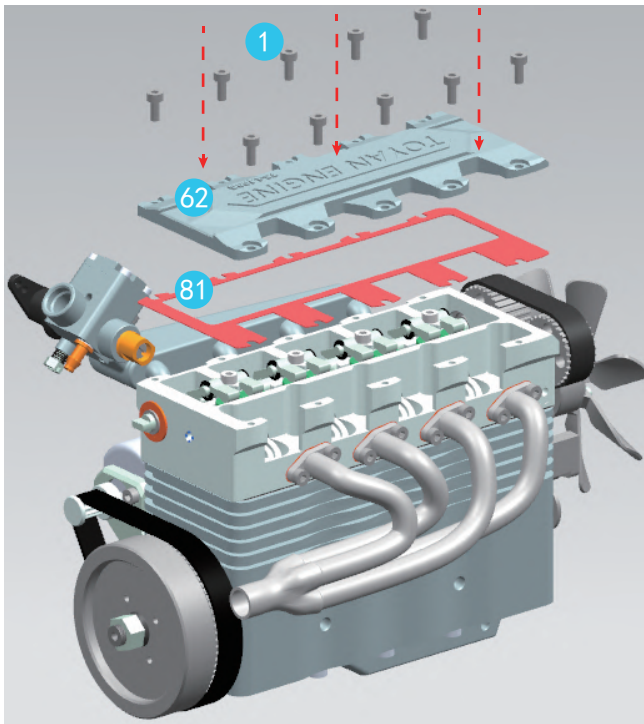

**If you want to operation, please add grease to the CAM before covering the cover to avoid dry friction.**

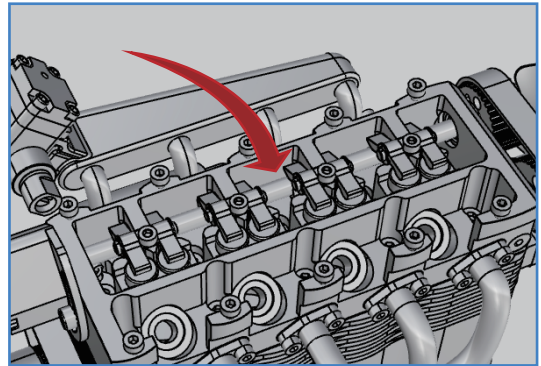

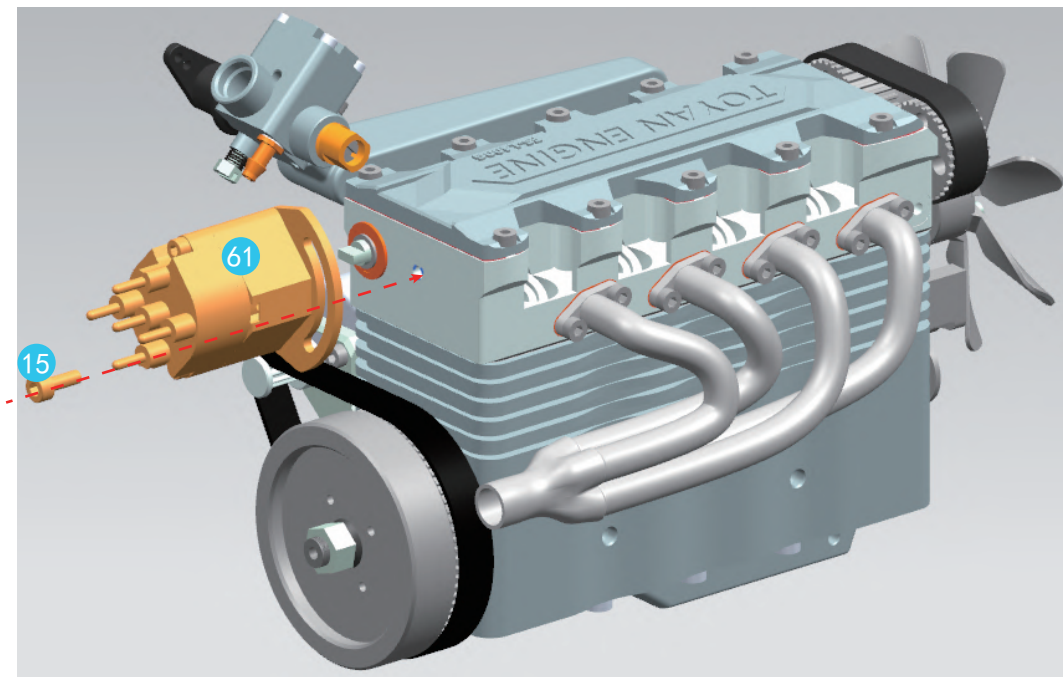



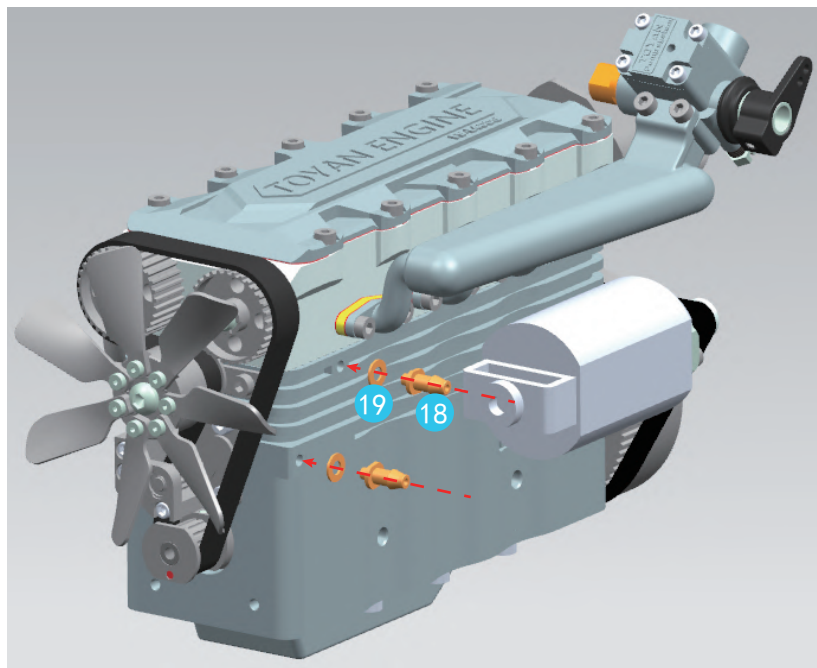

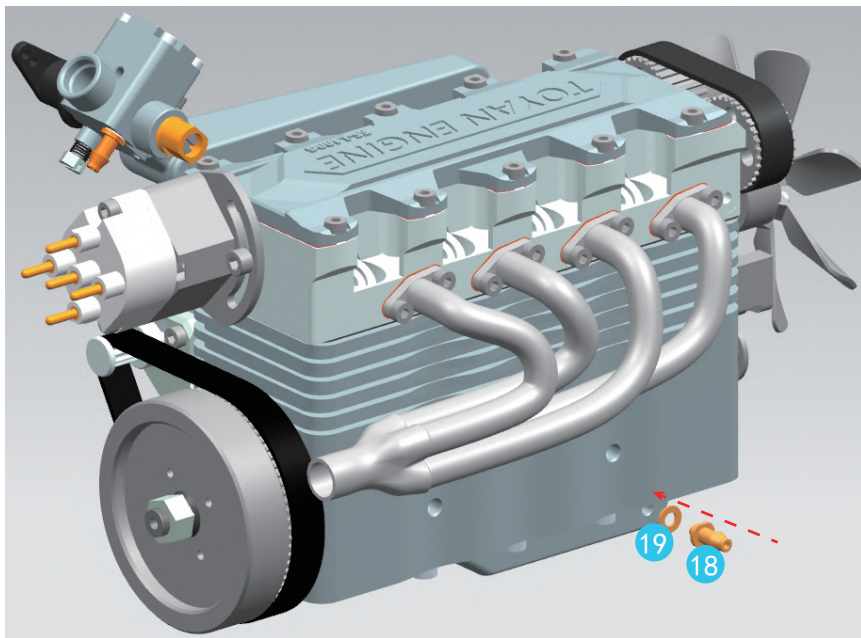

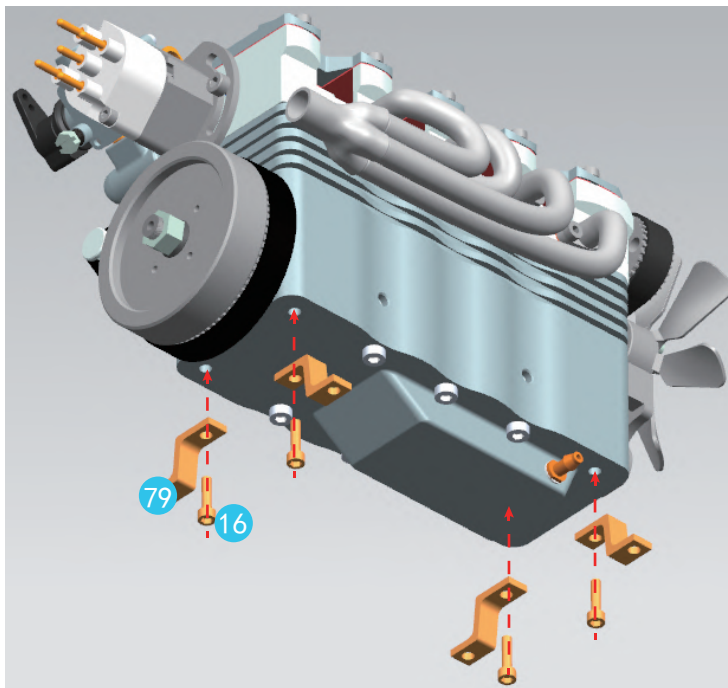

## Finished diagram

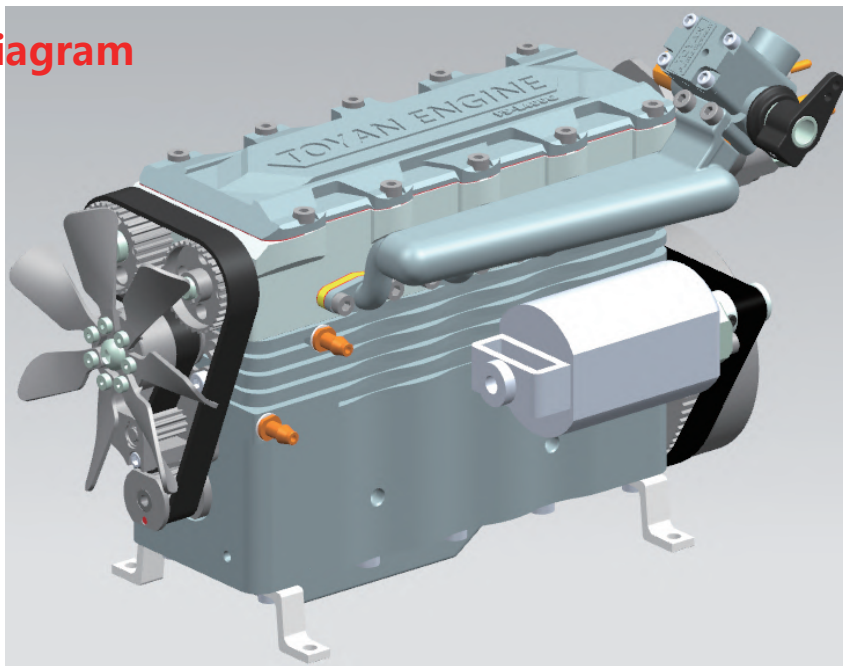

## INSTALL THE BASE

Make sure the surface of engine mounting is flush and in the same flat. Improper installation may lead to deformation of crankcase, bearing, etc. Unstable operation and performance degradation will happen. The 3.0mm hexagon socket screws are recommended when fixed engine. If installed on other engine platforms, please purchase adjustment pads to fit between the engine bracket and the engine.

## ATTENTION ABOUT STARTING

For the sake of safety, it is strongly recommended not to disassemble the engine and start the mechanism. If any starting problems, please contact your local dealer or TOYAN technician to solve them. If return to the factory for testing, TOYAN will provide you with high-quality after-sales service. If any problem caused by unauthorized disassembly, you will bear the corresponding responsibilities and expenses

### 1 Spark Plug

The series of FS-L400BGC requires four special spark plugs for a four-stroke gasoline engine. The spark plugs require a special CDI for ignition control. when hall detects display the piston running to the TDC, spark plug will be ignited, fuel will be ignition, then generate will acting.

## 2. Fuel

Please use gasoline engine fuel with guaranteed quality. Self-matching or fake fuel will greatly reduce the performance and life of the engine. As it is a four-stroke engine, in order to ensure the normal operation of the primer, please adjust the ratio of gasoline and fuel in the range of 1:25 to 1:30, and the oil uses 2T internal combustion engine oil.

### Remind!

**If the engine is running at very high speeds and on high nitro fuel, The life of the spark plug does not last long. Please note that engine fuel is toxic. Keep it out of contact with eyes or mouth and always store it in a clearly marked container and place, and keep out of reach of children. It is highly flammable. Keep away from open fires, overheating or any source of ignition**

## 3. Fuel tank

It is recommended to use a 100cc tank. The tank should be installed on the same flat as the engine. The gap between the fuel inlet & outlet of the fuel tank and carburetor should be kept within 1 cm (the carburetor must be higher than the fuel inlet & outlet of the fuel tank). If the gap is too high, the carburetor's working efficiency will be reduced and the engine will be started adversely. To ensure clean fuel supply, pls use standard 5mm silicone tubing and properly install oil filters. Since the engine itself relies on negative pressure to absorb oil, it is recommended the muffling exhaust pipe can be used to pressurize the fuel tank

#### **4. Start power supply**

The series FS-L400BGC has been installed with a start motor, which can be started with one button. You only need to purchase standard 7.4v 25C lithium battery to realize quick start. Too low or too high voltage of starting battery will not guarantee the service life of the starting motor, do not use incorrect voltage starting battery

#### **5. Environment for starting**

Please start the engine in an open, airy environment to avoid discomfort from burning gases

#### **6. Platform for Starting**

Since the engine will produce some vibration after starting, please place it on a stable and flat platform

#### **7. Heat dissipation**

Since the engine has been cooled by a fan, high-speed rotating fan blades will be dangerous, do not touch. If you find cracks in the blade during use, please replace in time

#### **Remind!**

Every time you start the engine, please carefully check whether there are cracks in the blades. we must replace new if any cracks to avoid the danger of blade spread out during high-speed operation

## OPERATION AND ADJUSTMENT

### Note

**Four-stroke engines have stronger torque output than two-stroke engines, so the corresponding measures should be taken during operation**

In order to extend the service life and improve the performance, each engine has been tested at the factory. You need to do proper running-in and cleaning after receiving the engine. After continuous running in, the cylinder pressure will be gradually strengthened. Due to the high simulation degree of this engine and the large number of various parts, we do not recommend you to fully disassemble the engine, we will provide a variety of effective sales to help you maintain and stable use

### 1. Check the timing belt and CAM axle box

Please make sure that the marking points on the two pulley can be down at the same time, see P43. Open the hood and add the grease. Since the mounted CAM is used, please add the solid grease to ensure stable operation and avoid dry friction of the CAM.

### 2. Check the power supply

Please confirm that the voltage of 7.4v universal ignition power supply is normal, and full of electricity

### 3. Initial Oil Needle Setting

The prerequisite is adequate lubrication and cooling. The engine is run with very important oil needle settings: The excess oil not only provides rich lubrication, but also conducts heat from the surrounding metal and further assisted by the fuel nitro methane. the two-stroke model



engines in pre-heating into the cylinder through the crankcase on a longer trip. But The four-stroke engine, with its intake pipe and carburetor mounted high on the cylinder cap, means that the rich mixture of cooling fuel and air will flow directly into the cylinder directly. With the help of fan cooling, it can provide excellent operation experience for every enthusiasts. You can also buy the TOYAN series of water cooling accessories, so that your engine will be able to maintain stable operation for a long time.

### **Remind!**

**When leaving the factory, each engine has completed the oil needle setting. If you have misadjusted the oil needle during the use, it is recommended to adjust the main oil needle to 2.0 laps and the auxiliary oil needle to 1.5 laps. Since the methanol engine needs to maintain the temperature of the spark plug filament to achieve ignition, when the engine is in the oil rich state for a long time at low speed, the temperature of the filament will gradually reduce, resulting in ignition difficulty. Therefore, it is necessary to up the speed for cleaning oil at intervals to avoid oil enrichment at low speed**

Since a four-stroke engine requires a lot of air intake, it is important to set throttle screws, the minimum throttle opening (idling setting) is about 1.5mm.,For the use of all kinds of engine enthusiasts. do not use a strong force to twist the throttle valve screws to adjust the size of the throttle door opening, but using valve screws to loose throttle, and then pull the throttle rocker arm to adjust. As shown in figure

Loosen the throttle screw and adjust the size of the throttle

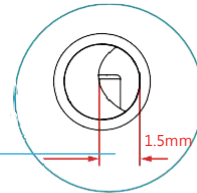
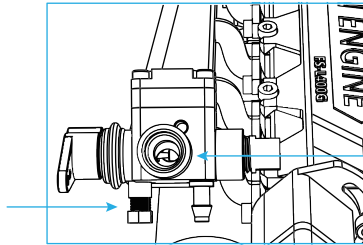

Please keep the throttle opening larger than 1.5mm

#### 4. Start

Remind!

It is important to put the throttle in the right position before starting the engine. It is recommended that the throttle be opened at 30% to start, the engine is not allowed to open the throttle too far under "no load" conditions, which can quickly overheat and can seriously damage the engine piston ring and cylinder sleeve.

Connect the spark plug battery and press the start button. Once the engine starts, disconnect the spark plug battery and keep the engine running slowly under the oil-rich needle setting. (If necessary, gently adjust the throttle lever to keep the engine idle steady.)

If the engine stops, cooling it for 15 seconds before restarting. Please hold down the start key within 5 seconds for each start, so as to protect the start motor life. Allow the engine to warm up for 30 seconds after starting so that the oil in the fuel can be fully lubricated to each working part. When the engine rapidly drops from high speed to low speed, or when low speed rapidly rises to high speed, the engine is unstable or the throttle control is slow or flashover, please confirm the carburetor working status

#### ● Rich oil

When the engine has more fuel, smoke is emitted or accelerates slowly, indicating that the engine has excessive oil, please turn the main oil needle clockwise,  $15^{\circ}$  as a unit, gradually reduce the main oil needle, until the sound of engine exhaust is soft and strong, and the exhaust pipe slightly smokes and the lubricates fuel spray out

#### ● Lean oil

If the sound of the engine is too sharp, like the sound of dry friction between metals, the temperature rises rapidly, and the engine is stopped immediately after acceleration, indicating that the engine has low oil, please turn the main oil needle counterclockwise,  $15^{\circ}$  as a unit, gradually reduce the main oil needle, until the sound of engine exhaust is soft and strong, and the exhaust pipe slightly smokes and the lubricates fuel spray out

#### Idling Stop

When the engine speed changes rapidly, suddenly adjust from the high speed to the low speed, the flameout occurs, please confirm whether the throttle is closed less than 1.5mm, or gradually reduce the auxiliary oil needle, (clockwise rotation) gradually adjust the auxiliary oil needle,  $20^{\circ}$  as units, until the engine maintains a steady idle speed. In the debugging process, the auxiliary oil needle should not be excessively reduced, so as not to cause engine have lean oil, we recommend that the minimum value of auxiliary oil needle should not be less than 1 turn.

## CARE AND MAINTENANCE

The series of FS-L400BGC is a very precise machine that you need to clean timely. Due to the impact of environment and the fuel when using, the engine parts have a certain amount of wear and corrosion. So, TOYAN will also provide you with long-term maintenance services. You can also complete the basic cleaning and maintenance

- Carefully clean the carburetor and remove dirt and grease from the inlet
- If an air filter is used, make sure the filter is clean and free from blockage
- Recommended that the air core used for more than one hour should be replaced in time. Be careful to remove contaminated filter elements to ensure that dirt does not enter the carburetor
- Do not remove timing synchronous belt, you can use alcohol as a cleaning agent to wipe the belt. Do not use corrosive detergent to clean synchronous belt, to avoid damage  
Glow Plug must be treated as consumables. Long running glow plug will not ensure the normal operation of the engine and you can extend its life maintain the performance of the engine if you use it carefully,
- ◆ Use appropriate tools for disassembly
- ◆ Use fuels containing a moderate percentage of nitromethane
- ◆ Do not overtighten the engine and do not connect the battery while adjusting
- The time to replace the glow plug. expect burned, It also need to be replaced on these situations because it no longer provides optimal performance,

For example:

- a. The surface of the filament becomes rough and white
- b. Filament curl deformation

- c.External material adhered to the filament or plug corrosion
- d.The engine will power off when idling
- e.The power went out after the engine started

At the end of each operation, empty the fuel tank, energize the glow plug, and try to restart the engine to burn the possible left fuel in the fuel tank. Repeat this process until the fuel is cleared from the engine.

Inject some antiseptic oil and briefly start the motor to distribute the oil to the working parts. Do not inject this oil into the lubricator nozzles, as this may cause the O ring of the carburetor to deteriorate Add solid lubricant to camshaft and valve tappet to ensure that the CAM axle box has enough lubricant for each operation

### Note!

**These maintenance programs will be stored after a period of time, and there is a risk of corrosion or startup difficulties, if you need someone to deal with, please contact us**

## Replacement of running parts

After long-term operation, the friction between the engine components will cause wear and too large gap, the replacement of related parts will help you maintain your engine better. When you are in the process of use, there is not flexible start, power reduction, idle speed instability and so on, please feedback your usage process and poor performance of the engine to the local dealer or TOYAN, we will serve you wholeheartedly. Parts replacement, we will provide professional equipment and experienced team. Please do not disassemble the engine without professional tools to avoid the risk of uncontrollable damage to the engine

## BUG CHECKING

If the engine fails to start, check the following carefully:

- Whether the battery voltage is normal, whether the power is full
- Whether the glow plug has failed
- Whether the fuel can reach the carburetor smoothly
- Do not start the engine when it is flooded. Remove the glow plug, close the oil needle and press the start button to drain the excess fuel. (Cover the plug hole with a piece of woolen cloth so that the fuel doesn't spill on you.) If forced to start without removing the excess fuel, it may cause irreversible damage to the starting system, as well as the connecting rod and crankshaft to strain and deformation
- Timing belt adjustment

All TOYAN engines have been tested for timing belt position before they leave the factory. After several hours of execution, the operating power loss or engine running instability is found, the timing belt needs to be tested and adjusted to get the correct ignition information for the engine. Please check against page 11 of "timing belt timing diagram"

When Turn off at low speed, do not keep it at too low speed a long time. Since the methanol engine needs to maintain the temperature of the spark plug filament to achieve ignition, when the engine is in a rich state for a long time at a low speed, the temperature of the filament will gradually decrease, resulting shutdown. Therefore, it is necessary wait a while to up the speed oil and clean the oil to keep the temperature of the filament

## Three views

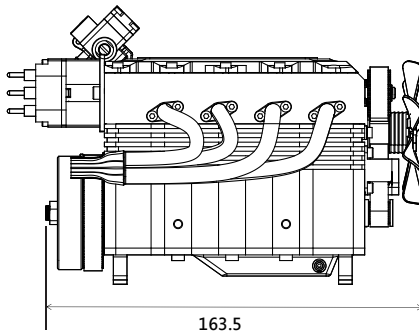
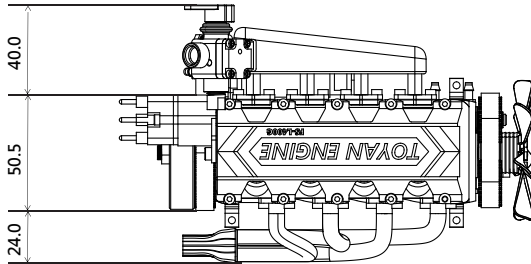

### FS-L400BGC Specification

- Displacement: 3.5cc × 4
- Bore: 16.60mm
- Stroke: 17.00mm
- Practical rpm: 3200–13500rpm
- Output: 3.05ps (30% Nitro)
- Weight: 1411g

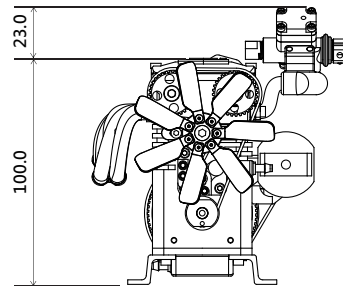

## Multiple view

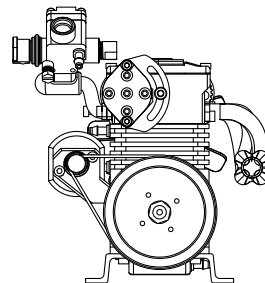
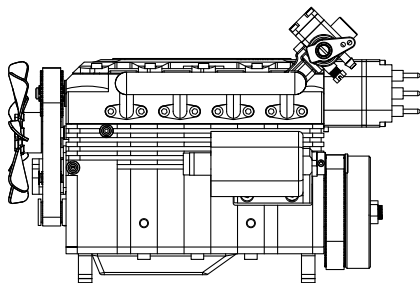
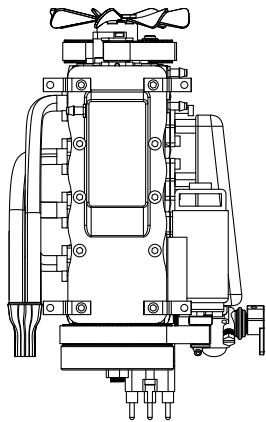



# Explosion view

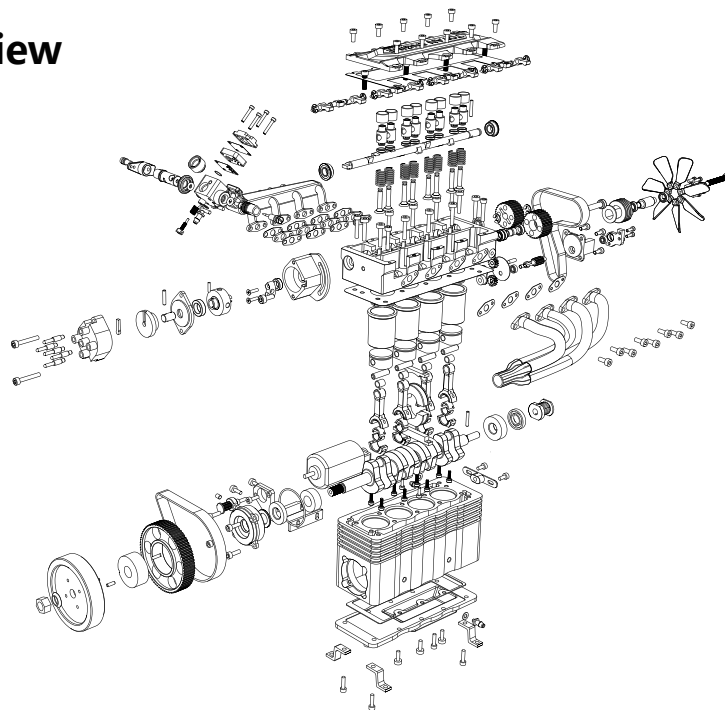

## Our Commitment

- Please contact a TOYAN dealer in your country or location. If you buy through the Internet, you can also get various parts and complete services through the Internet. Detailed information about each part can be obtained from the dealer
- In the process of use, we have a professional team to answer your technical or usage questions online for free.
- If your distributor is unable to perform its technical services, we will provide you with direct technical support

## 零件清單

NO.	物料名稱	PC	NO.	物料名稱	PC	NO.	物料名稱	PC
01	Screw(M2.5X6)	18	16	Screw(M3X10)	4	31	O ring (φ2.5)	1
02	Screw(M3X8)	2	17	Screw(M2X6)	3	32	Y type oil seal	1
03	Screw(M3X4)	2	18	Lubricating nipple	3	33	Bearing	1
04	Nut(M6)	1	19	Flat gasket (φ6)	3	34	Screw(M2.5X6)	4
05	Flat gasket	1	20	Exhaust pipe gasket	8	35	Water-cooled gear 2	1
06	Round pin(2X5)	1	21	Carburetor gasket (paper)	4	36	Water-cooled gear 1	1
07	Round pin(2X6)	1	22	Carburetor gasket	4	37	Gear gasket	1
08	Fan blade	7	23	E-type circlip (φ2.5)	12	38	Gear cover gasket	2
09	Gasket	1	24	E-type circlip (φ3.5)	5	39	Round pin(2.5X7)	1
10	Screw(M2X7)	10	25	Round pin(2X12)	1	40	O ring (φ1.4)	2
11	Screw(M4X25)	1	26	O ring (φ26)	1	41	O ring (φ2.5)	2
12	Screw(M4X16)	1	27	Screw(M2.5X8)	8	42	Cylinder block	1
13	Screw(M3X14)	10	28	O ring (φ8)	1	43	Cylinder cap component	1
14	Small screws(M3X14)	8	29	Screw(M2.5X12)	2	44	Exhaust pipe	1
15	Screw(M3X8)	6	30	Gear shaft	1	45	Cylinder liners and piston rings	4

NO.	物料名稱	PC	NO.	物料名稱	PC	NO.	物料名稱	PC
46	Air intake pipe	1	62	Engine Hood	1	78	Support frame 2	1
47	EG start	1	63	Pump carburetor	1	79	Engine bracket	4
48	Crankshaft component	1	64	Motor bracket	1	80	Ten-tooth adapter	1
49	Fan body	1	65	Synchronous belt (102)	1	81	Cylinder head cover gaskets	1
50	Gear covers	1	66	Synchronous belt (90)	1	82	Cylinder head gasket	2
51	Shaft position block	1	67	Camshaft flange bearings	2	83	Bottom gasket of casing	1
52	Flywheel	1	68	Camshaft oil seals	2	84	Auxiliary tools1	1
53	Mini belt roller	1	69	Camshaft	1	85	Auxiliary tools2	1
54	Timing pulleys	1	70	Motor bracket spacer	1	86	Crankshaft gaskets	1
55	Oil seal (outer diameter $\phi$ 16)	1	71	Belt tensioner	1	87		
56	Bearing (outer diameter $\phi$ 16)	1	72	Support collar 1 (no flat position)	1	88		
57	Bearing side covers	1	73	Support collar 2 (with flat position)	1	89		
58	Connecting rod component	4	74	Rocker arm	8	90		
59	Start belt pulley component	1	75	Rocker boom	4	91		
60	Bottom of the casing	1	76	Support frame 1	1	92		
61	Distributor components	1	77	Valve cover	8	93		