

# Essential Instructions

## Lemon 10 channel Telemetry-enabled Stabilized Receiver (LM0087)

- Description ..... 2
- Connections ..... 2
- Step 1: Powering the Receiver ..... 3
- Step 2: Binding the Receiver ..... 3
  - Binding Using the Bind Button ..... 3
  - Binding Using a Bind Plug ..... 4
- Step 3: Setting Failsafe ..... 4
- Step 4: Activating Stabilization – if required ..... 5
  - Programming the Receiver ..... 5
  - LED Identification ..... 5
  - Activating a Stabilization Option ..... 5
  - Stabilization ON/OFF Channel ..... 6
  - Stabilization Direction ..... 6
  - Stabilization Always-ON (Optional) ..... 6
- Step 5: Using Stabilization – if activated ..... 7
  - 1. Set up the transmitter ..... 7
  - 2. Bind the receiver ..... 7
  - 3. Test the receiver ..... 7
  - 4. Mount the receiver in the plane ..... 7
  - 5. Connect servos and speed control (ESC), set switches and wing type ..... 8
  - 6. Verify control directions, adjust centring and servo throws ..... 8
  - 7. Test stabilization response and direction ..... 9
  - 9. Set dual rates and expo in the transmitter ..... 10
  - 10. Adjust the stabilizer gain pots ..... 10
  - 11. Prepare for flying ..... 10
  - 12. Test fly ..... 10
  - 13. Fine tune stabilizer gain ..... 11
  - 14. Restrict Master Gain (if applicable) ..... 12
- Using Telemetry ..... 12
- Factory Reset the Receiver ..... 13
- Firmware Version ..... 13

## Description

The Lemon LM0087 10 channel Stabilized Receiver is intended as a “universal” integrated full range DSMX/DSM2™-compatible receiver. It combines full-range telemetry functions<sup>1</sup> with the well proven Lemon stabilizer technology to provide AS3X®-type stabilization.

The slim line case, 10 channels and built-in barometric sensor will be particularly attractive to glider pilots requiring complex wing surface functionality in a compact package. Rate Stabilization (“smooth out the bumps”) is optional and if activated can be switched on and off in the air; it is likely to be attractive to most users.

The Lemon stabilizer is relatively small and light. Despite its low cost, it offers long range and high performance with its “dual diversity” antenna system. A Lemon DSMP satellite receiver can be added to further enhance signal reliability but is not normally required.

The unit works with virtually any Spektrum or compatible transmitter with five channels or more<sup>2</sup>, including the first- and second-generation DX series, as well as the newer NX and iX transmitters. The receiver automatically switches mode between DSMX™ and DSM2™ as required.

An eight or more-channel transmitter with voice capability allows use of all the available functionality, but configuration options allow operation with radios having fewer features or channels. The Lemon 10 channel receiver also works with open-source transmitters such as Taranis and Turnigy 9XR using an add-on DSM2 or DSMX compatible module, as well as with Multiprotocol transmitters such as Jumper and RadioMaster.

Lower cost versions of the receiver with no stabilization function, or only 7 control channels, are also available.

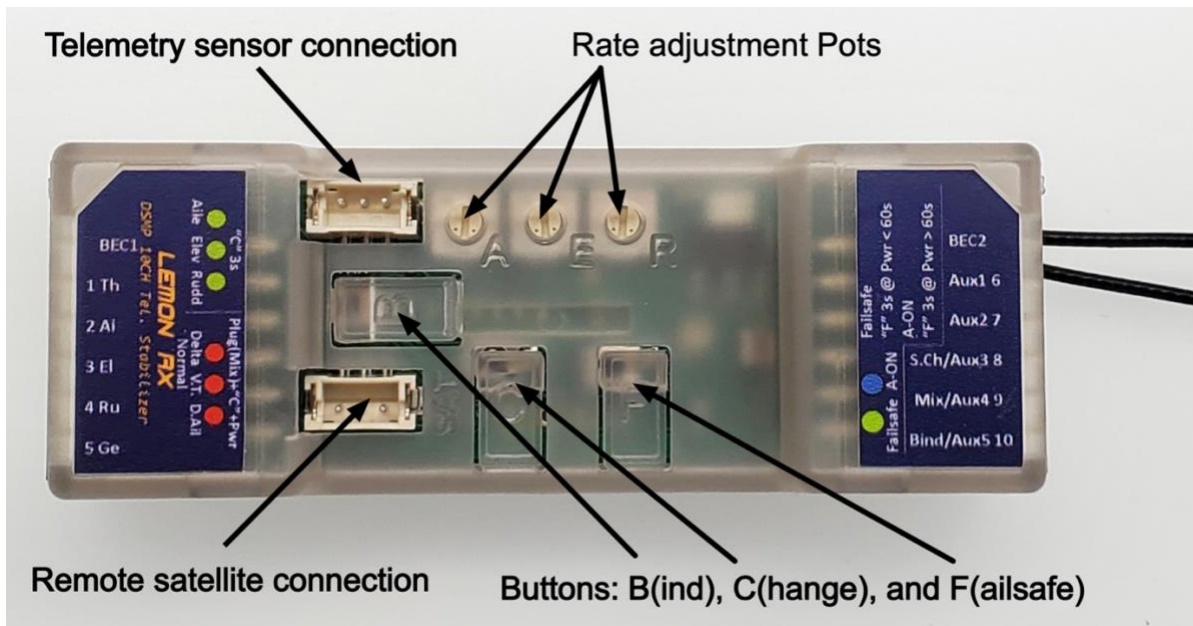

## Connections

The receiver has six sets of pins on each end of the case: on one end, channels 1-5 plus an optional isolated BEC (separate power source) input, and on the other, channels 6-10 plus another isolated BEC input. The channel 10 pins can also function as a normal bind plug connector. In addition, there are connectors for an optional satellite receiver and an optional voltage/current sensor or simple voltage probe for telemetry. Note that channel 1 and

<sup>1</sup> Essentially the same as those of the earlier Lemon LM0052, 7 channel receiver.

<sup>2</sup> Exceptions include the original DX6 Parkflier transmitter and the Orange T-Six DSM2.

channel 6 are the **second** set of pins and that the satellite and sensor connectors are identical. Don't mix them up. The receiver has a built-in barometric sensor which can provide altitude and vertical speed (vario) data.

As delivered, the Lemon 10 channel receiver has stabilization disabled and no internal mixes set. **Out of the packet it functions as a standard 10 channel DSMX/DSM2™-compatible receiver.**

To use the receiver without stabilization, the only setup you might want to do is to change the default No-pulse failsafe to User-set, as explained in Step 3 on page 4. In the unstabilized state, any other required programming, such as mixes, will be done in the transmitter as with any other regular receiver.

To activate stabilization, you need to program the receiver using the push buttons, as shown in Step 4, below.

### Step 1: Powering the Receiver

The receiver requires a power supply between 4.0v and 8.5v that can deliver the required current to the servos without dropping below 4v. The most common source is likely to be an ESC (Electronic Speed Controller) which will supply 5v to the receiver and servos. The majority of electric powered planes will use this arrangement and power will automatically be provided through the Throttle connection to channel 1.

The 10 servo connectors have common V+ and Ground pins, as is normal practice, although voltage is normally supplied on the Throttle channel from the ESC. However this receiver has, in addition, isolated independent BEC1 and BEC2 power input pins which permit different power arrangements which can increase reliability. (You can't use these connectors to supply power to anything – they are inputs only.)

The three common ways of powering the receiver are:

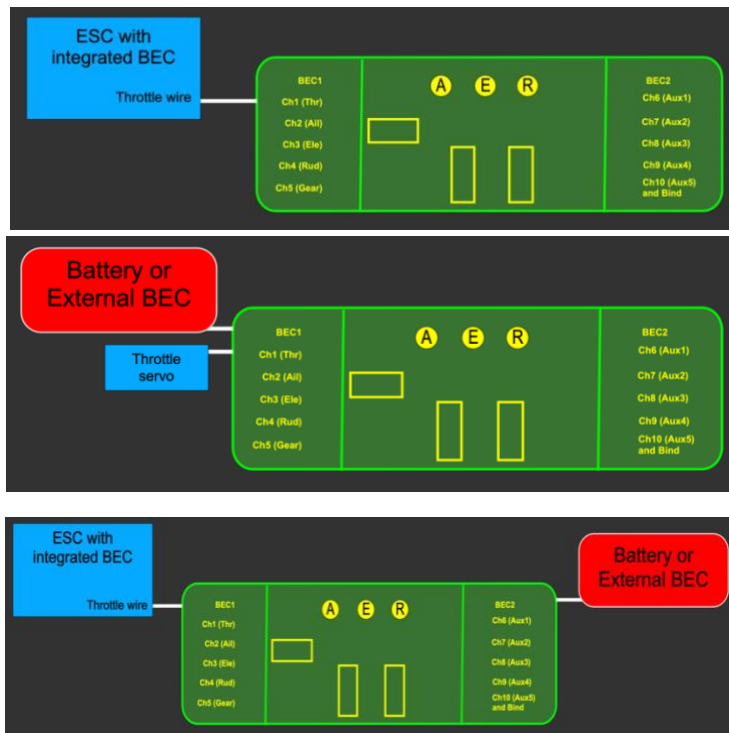

#### Via the Throttle Connector

Using an electronic speed controller (ESC) with inbuilt battery eliminator circuit (BEC). This is the most common method used for electric powered models. Connected to channel 1.

#### Via BEC1

Using an external battery or external BEC. The Channel 1 connector is used to control throttle via a servo (for IC power) or an ESC that does not have an integrated BEC. The power source is connected to BEC1

#### Via BEC1 and BEC2

Both BEC1 and BEC2 can be used simultaneously without the usual concerns about conflicting voltages. An ESC with integrated BEC feeds power through BEC1 while a supplementary power supply is connected to BEC2. Note that no connection to channel 1 is needed as the throttle signal is routed automatically from BEC1.

### Step 2: Binding the Receiver

To bind the receiver to a specific model memory in the transmitter, use either one of these two methods:

#### Binding Using the Bind Button

1. Power ON the receiver (with satellite receiver connected, if used).

2. Hold down the Bind button B for about 3 seconds.
3. Release button B when the red Receiver Status light starts to flash.
4. If a satellite receiver is used, power cycle the receiver at this point by removing power and applying it again. Both the receiver status light and the satellite light will then flash.
5. Proceed to bind to the transmitter in the normal way (see transmitter instructions).
6. Bind is complete when the red Receiver Status light (and satellite light, if connected) are solid.

### *Binding Using a Bind Plug*

(The traditional, older Spektrum™ method)

1. With receiver power OFF, place a bind plug on the channel 10 pins.
2. Power ON receiver (with satellite receiver connected, if used).
3. The red Receiver Status light and satellite, if connected, will start to flash.
4. Proceed to bind the transmitter in the normal way (see transmitter instructions).
5. Bind is complete when the red Receiver Status light (and satellite light, if connected) are solid.
6. Don't forget to remove the bind plug.

The receiver is now ready for use with stabilization inactive; however adding User-set failsafe is recommended.

## **Step 3: Setting Failsafe**

No-pulse mode is the default response of the receiver as supplied if signal is lost for approximately 1 second or more. The receiver ceases to send pulses on any channel. Servos stay in their current positions, while the ESC, after a brief delay, will normally shut down power to the motor.<sup>3</sup>

By contrast, the User-set failsafe option causes the receiver on loss of signal to send a pre-set value to each of the servos and the ESC.

No-pulse failsafe is adequate for most electric powered models. User-set failsafe is often preferred, however.

To activate User-set Failsafe, proceed as follows:

1. Power ON the transmitter. Set sticks and switches to the positions required on loss of signal.
2. Power ON the receiver.
3. After 3 seconds **but within 60 seconds** of powering ON the receiver, press and hold Failsafe button F.
4. Release button F when the green Setup LED turns ON, showing that the receiver has registered the failsafe values.
5. Test failsafe (carefully) by turning off the transmitter (on the bench, not in flight!).

The receiver will retain the failsafe values until the procedure is repeated or the receiver is reset.

To cancel User-set Failsafe:

1. Power ON the receiver. If User-set Failsafe is active, the green Setup light will be ON.
2. After 3 seconds but within 60 seconds of power ON, press and hold button F.
3. Release button F when the green Setup LED turns OFF, indicating No-pulse mode.

## **Setup, if you are not wanting to use the stabilization function, is now complete.**

Just a check: stabilization is **not** active if the red programming LEDs R1, R2 and R3 shown in the diagram under "LED Identification" on page 5 are **not** lit. This is how the receiver is delivered.

---

<sup>3</sup> Some ESCs may behave differently; be sure to test yours.

## Step 4: Activating Stabilization – if required.

### Programming the Receiver

If the three red Programming LEDs (in a row in the center of the receiver) are all OFF, stabilization is NOT active, and the receiver operates as a standard 10 channel DSMX/DSM2™ compatible receiver.

Activating stabilization requires programming the receiver, as explained below. Note that if stabilization is active, certain mixes, notably Delta Wing (elevons) and V-Tail, MUST be done in the receiver, not the transmitter.

**WARNING: If doing any programming of an electric powered model with the motor connected, please remove the propeller for your safety!**

### LED Identification

All setup is done by using the three buttons (B, C, F), and for some functions, a bind plug on channel 8 or 9. Individual stability gain adjustments for Roll (Aileron), Pitch (Elevator), and Yaw (Rudder) are done with the three rotary “pots” labelled A, E and R in the diagram below.

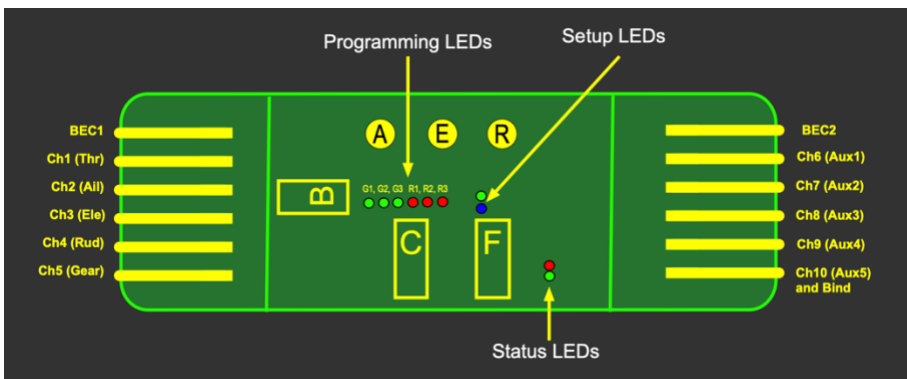

The diagram identifies the buttons, pots (potentiometers) and various indicator LEDs. Please review it carefully.

With the receiver powered ON, locate the three green and three red programming lights (G1, G2, G3 and R1, R2, R3).

Press button C for no more than 2 seconds to identify these lights.

Also locate the position of the blue and green Setup lights and the red and green Status lights, as shown in the picture.

### Activating a Stabilization Option

To activate stabilization, the receiver must be programmed with one of five optional configurations, indicated by the three red programming LEDs: R1, R2 and R3. The options and the corresponding lights are as follows:<sup>4</sup>

- Option A: Delta Wing (Elevons) – R1
- Option B: V-Tail – R2
- Option C: Normal (conventional tail) – R1+R2
- Option D: Dual Aileron Channels with normal tail – R1+R2+R3
- Option E: Dual Aileron Channels with V-Tail – R2+R3

To set a Mix option, proceed as follows (the transmitter is not required except to test results of programming):

1. With the receiver OFF, place a Bind Plug on the channel 9 pins.
2. Press button C and hold while powering ON the receiver.
3. Release button C when all six programming LEDs flash (three red, three green).
4. Red LEDs will now turn on for 3 seconds in sequence: R1, R2, R1+R2, R3.

<sup>4</sup> Those familiar with the previous Lemon RX stabilized receivers will recognize that the green Stabilization Direction LEDs are equivalent to DIP switches J1, J2, and J3, while the three red Programming LEDs correspond to J4, J5 and J6.

5. When the desired option is reached, tap button C once.
6. Immediately tap button C again to change the state of the option from OFF to ON.
7. Allow the receiver to exit from Mixing mode.
8. If appropriate, repeat the process to set dual aileron channels (R3) in the same manner.
9. Remove Bind Plug from channel 9 pins.

Example: Option D is required to stabilize a model with normal tail and dual aileron channels. Start by setting Option C (R1+R2). Then, in a separate operation, set R3. The result will be all three red programming lights ON.

Note that either R1 or R2 or both must be ON for stabilization to be active. Thus, setting R3 without either Option B or Option C will have no effect. Settings are retained even when power is removed.

Once a stabilized option is set, stabilization can be turned on and off in flight by a switch on the transmitter. When stabilization is ON, the green Status light will be illuminated.

### *Stabilization ON/OFF Channel*

By default, Stabilization ON/OFF is controlled by a switch assigned to CH7 (Aux2). To change this to CH5 (Gear), proceed as follows:

1. On the transmitter, make sure a suitable switch is available on the desired channel.
2. With receiver OFF, place a Bind Plug on the channel 8 pins.
3. Press button C and hold while powering ON the receiver.
4. Release button C when all six LEDs flash (three red, three green).
5. The Setup lights briefly show which channel is being used currently: Green = CH7, Blue = CH5.
6. To change, tap button C.
7. Allow the receiver to exit from this mode and power OFF. Remove Bind Plug from channel 8 pins.

Turn on the receiver and test operation of the transmitter switch on the selected channel. The green Status light should now show whether stabilization is ON or OFF.

Note that when stabilization is activated, CH8, if available on the transmitter, is dedicated to the Master Gain function and not usable for other purposes.

### *Stabilization Direction*

If stabilization is active, it is **ESSENTIAL** that control surfaces move in the correct directions to counteract disturbances; reversed stabilization will probably cause a crash. Control directions in response to stick movement are set in the transmitter, but stabilization directions are set in the receiver, as follows:

1. With receiver powered ON and without any bind plug, press and hold button C for about 3 seconds.
2. Release button C when all six LEDs flash (three red, three green).
3. Each green LED will now turn on for 3 seconds in this sequence: G1 (Ail), G2 (Ele), G3 (Rud).
4. When the LED for the surface to be reversed is reached, tap button C to select it.
5. Immediately tap button C again to reverse the stabilization direction.
6. Allow the receiver to exit from Stabilization Direction mode.
7. Repeat as required for other surfaces.
8. Test that stabilization directions are correct on all axes (see page 9).

### *Stabilization Always-ON (Optional)*

Setting the receiver to Always-ON mode allows the Stabilization ON/OFF channel (7 or 5) to be freed up for other purposes. The green Status light indicates that Always-ON has been set.

Given an eight or more-channel transmitter, even with Always-ON active Stabilization can still be turned down to a negligible level by setting CH8 (Master Gain) to -100% (for zero gain, CH8 must be at -150%).<sup>5</sup>

To set Stabilization Always-ON, proceed as follows:

1. Make sure the receiver is programmed to one of the five options listed above (page 5).
2. With Transmitter ON and receiver bound, power receiver ON and **wait at least 60 seconds**.
3. Press and hold Button F until the blue Setup light turns ON. Release button.
4. The green Status light should now also be ON to indicate stabilization active.

To cancel Always ON, repeat. Hold Button F until the blue Setup light and the green Status light turn OFF.

Note that the green Stabilization Status light is not as bright as the adjacent red Receiver Status light and so can be harder to see.

## Step 5: Using Stabilization – if activated.

The following assumes that you are using a Generation 2 or later Spektrum transmitter and that you have already programmed the receiver with one of the stabilization options explained above. Using the receiver with other transmitters is discussed in a separate document, “Additional Information”. [\[LINK\]](#)

It is usually most convenient to complete receiver programming (Step 4, above) and items 1 to 3 below before mounting the receiver in the plane.

### *1. Set up the transmitter*

Set up a new model in the transmitter or reset an existing model. In particular, disable any delta wing (elevation) or V-tail mixing in the transmitter – if these mixes are required, they must be done in the receiver when stabilization is active. Make sure control throws (end points/limits) are set to 100%.

Set up a switch on channel 7 (or optionally on channel 5) to control Stabilization ON/OFF.

Set up channel 8 (if available on your transmitter) to be controlled by a knob or slider for Master Gain.

### *2. Bind the receiver*

Bind the receiver to the transmitter, as explained above (Step 2).

### *3. Test the receiver*

Power up the transmitter then the receiver

The red Status LED should be ON. Check that the Stabilization ON/OFF switch works correctly.<sup>6</sup>

Temporarily plug a servo into each of the Ail, Ele, and Rud outputs and check that they operate normally in response to the correct transmitter sticks. Power OFF.

### *4. Mount the receiver in the plane*

The receiver can be mounted upright or inverted and must be aligned with the direction of flight. Either set of servo connectors can be at the front. It will not work properly if mounted across the fuselage, on edge, tilted forward or backward, or at an angle to the centre line. This receiver, unlike some other stabilizers, does not need to be mounted particularly close to the centre of gravity of the model.

<sup>5</sup> Even with stabilization turned down to zero gain, Delta Wing or V-Tail mixing must NOT be done in the transmitter.

<sup>6</sup> The green Status light on the receiver will be OFF if the channel 7 is at 0% or 100%. If channel 7 is at -100%, It will be ON, indicating that stabilization is active.

Ensure that the active portions of the two main antennas (the silver section about 31mm long) are well separated from each other and from conductive items such as wiring, battery and carbon fibre. They should be approximately at right angles to each other. Take care not to kink the cables.

The receiver must be firmly mounted to the structure of the aircraft with the double-sided mounting tape supplied or other vibration-absorbing material. It must not be able to wobble or come loose in flight. Hook-and-loop material can be used, but only if care is taken to ensure that this requirement is met.

Given the dual diversity antenna setup of the Lemon receiver, a satellite receiver is not normally required, but can be used if desired for extra signal reliability. It should be well separated from the main receiver.

Make sure you can access the three gain pots on the receiver, as you will need to adjust them after test flights, perhaps repeatedly.

**5. Connect servos and speed control (ESC), set switches and wing type**

Plug the servos and ESC into the appropriate slots on the receiver. For information on options for powering the receiver, see Step 1 (page 3). Normally, the Stabilization ON/OFF channel slot (channel 5 or 7) will be empty, as it is used internally by the receiver, as will the Master Gain slot (channel 8).

On the transmitter, set wing type (in the Aircraft Type menu) as shown below; in all cases, the tail type is Normal, even for a V-Tail model.

**Important safety warning: Leave the motor unconnected or remove the propeller when programming or testing an electric powered model. Electric models can bite!**

Model Type	Channel Assignments								Wing Type	Stabilizer LEDs		
	1	2	3	4	5	6	7	8		R1	R2	R3
Conventional (one Ail channel)	Thr	Ail	Ele	Rud	*		On/Off	Master Gain	Normal	✓	✓	X
Conventional (two Ail channels)	Thr	RAil	Ele	Rud	*	LAil	On/Off	Master Gain	Dual Ail/ Flaperon	✓	✓	✓
Delta Wing (Elevons)	Thr	RElev	LElev	Rud	*		On/Off	Master Gain	Normal	✓	X	X
V-Tail (one Ail channel)	Thr	Ail	RTail	LTail	*		On/Off	Master Gain	Normal	X	✓	X
V-Tail (two Ail channels)	Thr	RAil	RTail	LTail	*	LAil	On/Off	Master Gain	Dual Ail/ Flaperon	X	✓	✓

\* Used for Stabilization On/Off on 6 channel transmitters; otherwise used as a normal servo output.

**6. Verify control directions, adjust centring and servo throws**

1. Power ON. Use the Stabilizer ON/OFF switch to turn stabilization OFF (green Status light OFF). Be sure you know which way is OFF in case you need to use it in a hurry!
2. Adjust transmitter reversing so that all servos work in the correct direction in response to the sticks. Note that where elevon, V-tail or flaperon mixing is involved it may be necessary to interchange the two servo connectors and/or reverse controls to get the correct action.
3. With trims in neutral, adjust servo arms and linkages to align your control surfaces. Use only a minimum of subtrim on the transmitter for fine tuning. Servo arms should be at right angles to push rods to ensure equal movement in both directions.



4. With end points (limits) and control rates at 100%, check that control surface throws are at the recommended maximums for the model and adjust linkages if necessary. Note that adjusting throws in the transmitter will not affect stabilization responses, so throws need to be set mechanically to give the stabilizer an appropriate amount of control; the exact amount is not critical, as gain will later be used to adjust stabilization, but it should be reasonably close.

### 7. Test stabilization response and directions

Turn the three on-board gain adjustment pots fully clockwise to maximize action.<sup>7</sup> Set the Stabilizer ON/OFF switch to ON (green Status light ON). Sharply move the plane in each of the three flight axes and verify that the control surfaces move momentarily to oppose the disturbance. See diagram below.

**HINT:** If you find it hard to see the response direction, put your finger on the hinge line of the control surface. It is easier to feel a short pulse than see it.

Direction of servo movement with changes in direction when stabilizer is enabled

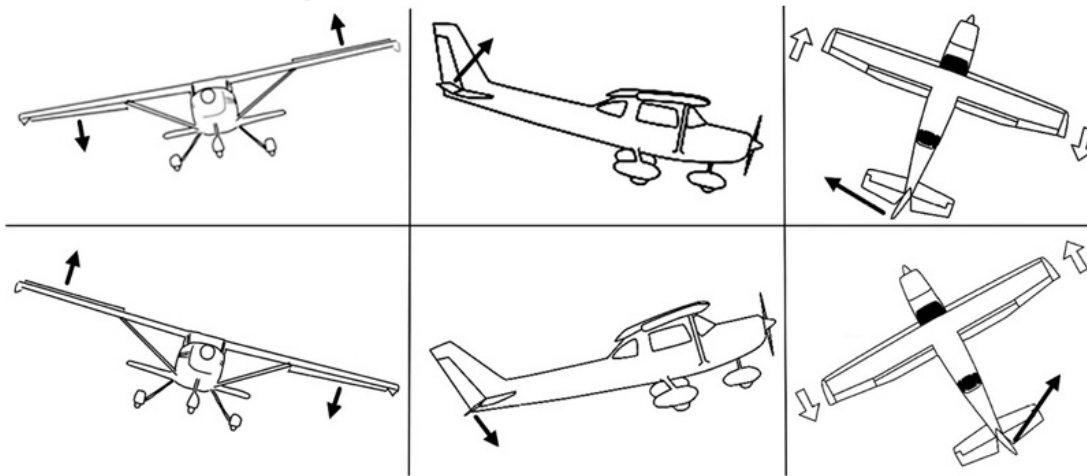

The diagram shows how the surfaces should respond with a momentary pulse to movement of the model about each axis. When the model is rolled sharply to the right, the right aileron should go down and the left aileron up to resist the displacement. Likewise, when the model pitches nose-down, the elevator should go up to compensate. And when it yaws nose-right, the rudder should go left.

Remember that this receiver provides rate stabilization, not auto-levelling. Thus, when testing, the control surfaces will only be displaced while the model is being disturbed. As soon as angular motion stops, they will return to neutral. Hence, look for quick twitches of the control surfaces in the right directions, not prolonged control offsets.

#### THE FOLLOWING IS VITALLY IMPORTANT:

***If stabilization moves any of the surfaces the wrong way (i.e., to increase the disturbance), your model may be uncontrollable (until you switch off stabilization)!***

To correct this, change the appropriate stabilization response direction indicated by the 3 green LEDs: G1 (aileron), G2 (elevator) or G3 (rudder). Instructions on how to program the receiver to do this are in Step 4 on page 6.

<sup>7</sup> If you are using channel 8 for Master Gain, set it temporarily to the middle or high end of its range.

Just as experienced RC pilots check stick directions before the first flight of the day, so a pilot using a stabilizer should check that the surfaces move correctly in response to a disturbance.

### 9. Set dual rates and expo in the transmitter

With the control surfaces set to move in the correct directions and with the full throws recommended for your model, you can now adjust the response to transmitter stick inputs by setting dual rates (D/R) and expo.

A good starting point for D/R is to set High Rate to 100%, Mid-Rate (if available) to 80-85%, and Low Rate to 65-75% for each axis. Expo of around 20% softens response around neutral and can make smooth flying easier. These settings can be adjusted to your liking after the initial flights.

Stabilization settings also affect the response of the model to transmitter input, typically somewhat reducing sensitivity with an expo-like effect.

Note that the dual rate and expo settings in the transmitter determine stick response but **don't affect** how stabilization works. That is entirely done within the receiver.

### 10. Adjust the stabilizer gain pots

As delivered the stabilizer gains are normally at the 12 o'clock position. For first flights set the three gain pots at about the 10 o'clock position. This is a good conservative starting point that should produce noticeable stabilization. For most models, at least one or two gain adjustments will be needed during flight testing to achieve optimum stabilization.

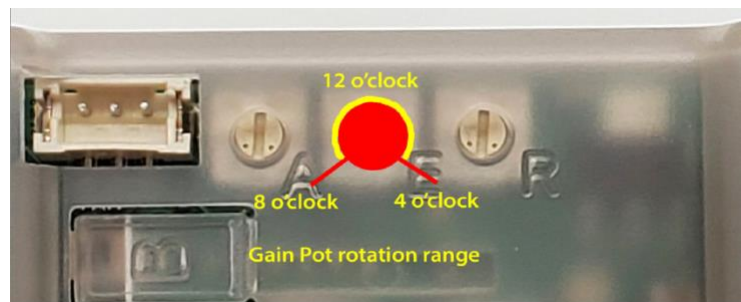

### 11. Prepare for flying

Check that the balance of the model is correct according to the manual.

Check the control directions and stabilization functions one more time.

Do a reduced-power range test as directed in the transmitter manual (should give at least 30m/100 feet range with full control).

Check that the switch is operating correctly to turn stabilization OFF (red Status light only) and ON (green and red Status lights). Yet again, make sure you know which way is OFF!

Test failsafe operation by running the model (well secured) at about half throttle and turning off the transmitter. With the default No-pulse setting, the motor of an electric-powered model should stop after a couple of seconds and the control surfaces should stay in their current positions. User-set Failsafe (as described in Step 3 on page 4) moves ALL channels to pre-set failsafe positions. This may be preferred for an electric model and is mandatory for an IC (fuel-powered) model.

If you have Master Gain on channel 8, check that it is set to the middle of its range and that increasing the control knob or slider increases the resulting stabilizer reaction. Reverse the channel output if not.

### 12. Test fly

For safety, always start a test flight with the stabilizer turned OFF (green Status light OFF).

Power ON the model.

Take off and fly around, adjusting trim as necessary to make sure the model flies properly without stabilization. If trim is very far off neutral, land and make mechanical adjustments.

When satisfied, and at a safe height, turn the stabilizer ON. If the model rolls, dives or turns suddenly, at least one of the gyro directions (LEDs G1, G2, G3) is incorrectly set. Switch OFF the stabilizer immediately! Land and fix.

Likewise, if you encounter major oscillation, usually in high-speed flight, either land and reduce gain on the axis/axes involved, or, if Master Gain is available, dial it down to the point where oscillation stops.

Assuming the model does nothing scary that you can't deal with, continue flying to explore the action of the stabilizer. Do a shallow dive to pick up speed and watch for oscillation on one or more axes. If it happens, just throttle back and slow down (oscillation is quite different from control surface flutter and is generally not destructive unless extreme).

Notice how the model handles with the stabilizer turned on. It may be less responsive on one or more axes. Try out your dual/triple-rate settings. Turn stabilization off and on to get familiar with its effects. If you have Master Gain, cautiously explore higher gains.

By the time you've finished the initial flight(s) you should have a good sense of the model's stabilization behaviour and have achieved flyable basic settings on the receiver.

### *13. Fine tune stabilizer gain*

Optimal stabilization occurs when gain on each of the three axes is just below the level where oscillation occurs at the highest normal flying speed. This requires a series of flights to tune the individual gain settings, with repeated landings to adjust the receiver pots, followed by retesting in flight. Many people, however, find that a "quick and dirty" setup, with minimal adjustments to the settings provides adequate stabilization for every day flying, but it's a good idea to experiment a bit.

If you have an 8+ channel transmitter, Master Gain can accelerate the process of optimizing gain. For example, you can, one by one, turn down the gain pots on two axes and experiment with various levels of Master Gain on the third. It's best to aim for a Master Gain setting around 0% (in the middle) for normal flying.

If you don't have Master Gain, here's one possible approach to optimization:

1. Increase the Rudder pot setting by about one to two "hours" (15-30°).
2. Take off with stabilization OFF. Turn ON at a safe height. Watch for oscillation on the yaw axis ("tail wag"). Do a shallow dive to pick up speed and again watch for oscillation.
3. Land and adjust the rudder pot as required. If there was no oscillation, even when diving, turn the pot up another "hour" or so. If there was oscillation, turn the pot down a similar amount.
4. Test and repeat as necessary.
5. Now do the same procedure for the elevator gain pot.
6. Finally do the same procedure to set the aileron gain pot.

Usually, the aileron pot requires the lowest setting (typically below 11 o'clock), with elevator in the mid-range and rudder highest of all. However, the settings can vary considerably with factors such as design, flight speed and control surface setup.

**HINT:** It's best to do the initial setup and tuning in fairly calm conditions to avoid confusing stabilizer-induced oscillation with buffeting caused by turbulence. Once adjusted, test the effectiveness of stabilization by flying in windier weather, turning stabilization on and off and adjusting Master Gain. You should see a noticeable improvement in smoothness.

### 14. Restrict Master Gain (if applicable)

Master Gain is very useful to allow for varying wind conditions. But you don't want to accidentally set it to very high gain, which can cause disconcerting oscillation. Hence, once you've set up the receiver pots with the Master Gain knob or slider about the middle, you may want to limit the maximum available Master Gain.

The simplest way is to use Travel on the Servo Setup menu to limit the throw on channel 8 (Aux3) to, say, 20% on the high side, (numbers -100, 20).

Another way is to use Channel Assign to change channel 8 (Aux3) to control by a switch, then use Digital Switch Setup to set it to, say, -20%/0%/10%. Adjust the values as required to give a suitable choice of three settings. Note that those particular settings are good for flight but don't allow Master Gain to be used to effectively shut down stabilization and thus should probably not be used together with Always-ON.

## Using Telemetry

Telemetry is independent of stabilization and can be used with the receiver in stabilized or unstabilized configuration.

A separate document "Telemetry with the Lemon Rx 7- and 10-Channel Receivers" [\[LINK\]](#) explains in detail how to setup and calibrate the Telemetry function. This section just mentions some highlights.

The Lemon Telemetry Receiver sends data on receiver voltage, temperature and RSSI (signal strength)<sup>8</sup>, plus altitude and vertical speed (vario) information from a built-in barometric sensor. Flight battery data can be provided by a voltage sensing wire or the optional V/I (voltage and current) sensor; the latter enables the transmitter to calculate battery capacity-used (mAh). Lemon telemetry is displayed using the existing display screens and, where available, the transmitter's voice capability.

The transmitter can set alarms, in some cases just tones but often voice announcements. For example, an alarm tone and warning can sound when the flight pack voltage drops to a preset value or if the model exceeds a certain height above ground.

To utilize this capability on a telemetry-enabled Spektrum™ transmitter, turn on the radio and power ON the receiver. Go to Telemetry. You will see a display of parameters potentially available from the installed sensors. Run "Auto-Config" if they do not appear.

The Settings item allows selection of either metric or US units.

To determine how the various parameters are used by the transmitter, go to any one of the items and double click. You will then see a screen offering several options, which vary from one item to another. Typically, the choices allow maximum and minimum values to be set for purposes of triggering alarms and voice reports to be made at regular intervals or when a switch is flipped. Note that not all of the parameters displayed on the Telemetry screen will turn out on inspection to be functional and useful.

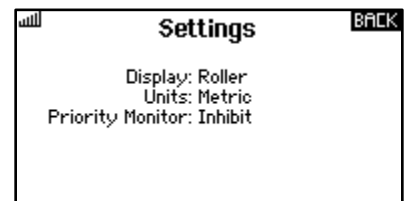
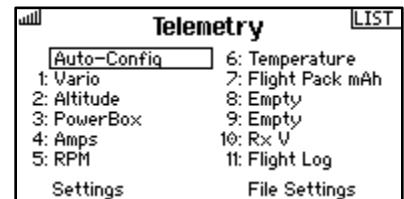

<sup>8</sup> Note that the Lemon RSSI value cannot be directly compared to other signal indicators, such as Spektrum™ fades or an FrSky™ RSSI number. Lemon RSSI will read close to 100 with the transmitter beside the model and fall as the model moves away. Even at the minimum reading approaching 20, the signal should be adequate for control.

Examples of the options available are shown in the pictures below.

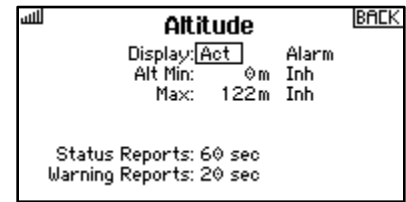
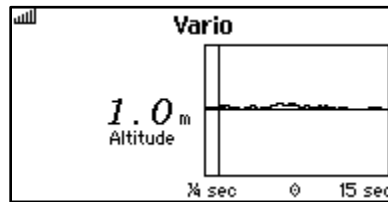
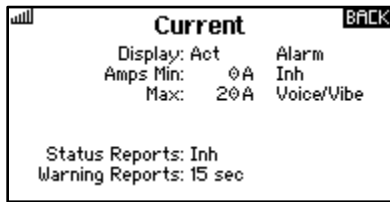

On the main screen of the transmitter, you can scroll through the available telemetry screens using the roller.

The transmitter can record the telemetry data on the SD card for later review, a potentially very valuable feature in the event of problems. This is set up using the File Settings item on the Telemetry screen.

For detail on all these capabilities and more, see the separate document “Telemetry with the Lemon RX 7 and 10 Channel Receivers”.

## Factory Reset the Receiver

A reset will cancel all programming and other settings, leaving the receiver in simple, unstabilized status. The transmitter is not required for this operation.

1. With the receiver ON, press and hold Button B and Button F simultaneously for about 6 seconds.
2. Release the buttons when all receiver LEDs flash.
3. Press Button C briefly. The receiver will flash for about 1 second, then reboot.
4. Reset complete. No lights showing.

Note that Reset does not clear an existing bind.

## Firmware Version

Lemon receivers are not user updatable, but if you need to contact Lemon it will be useful to know the exact date of the firmware on your receiver.

When the receiver is powered on, the firmware date is displayed briefly on the initial telemetry screen in the format: B (year), L (day) and R (month).

For example, this receiver has firmware version 2022 10 June.<sup>9</sup>

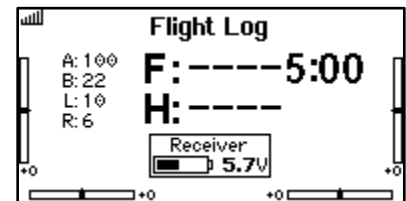

<sup>9</sup> A represents the RSSI value. B, L and R normally show 0, except when displaying the firmware date.