



## 1/18 Utility Trailer LED Light Kit Installation Instructions

Covers Part #9790

- A. Feed the left and right LED tail light housing assemblies from the toolbox through the trailer frame.

B. Position the power wiring harness into the slot in the front of the toolbox as shown.

C. Place the toolbox on the trailer frame and push down until it snaps into place.

### Kit contents:

- Toolbox (with LED tail lights wiring harnesses and housing assemblies)
- 3x6mm countersunk cap screws (CCS) (2)

- Rubber wire plugs (6)
- Y-harness
- Wire mount

### Tools required:

- 2.0 mm hex wrench

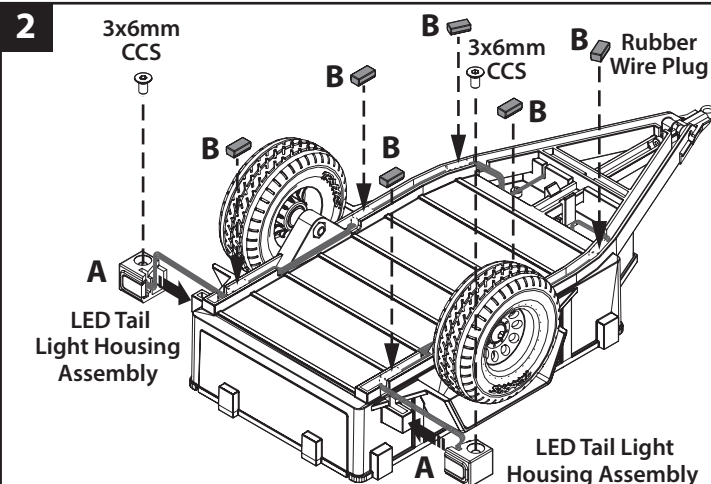
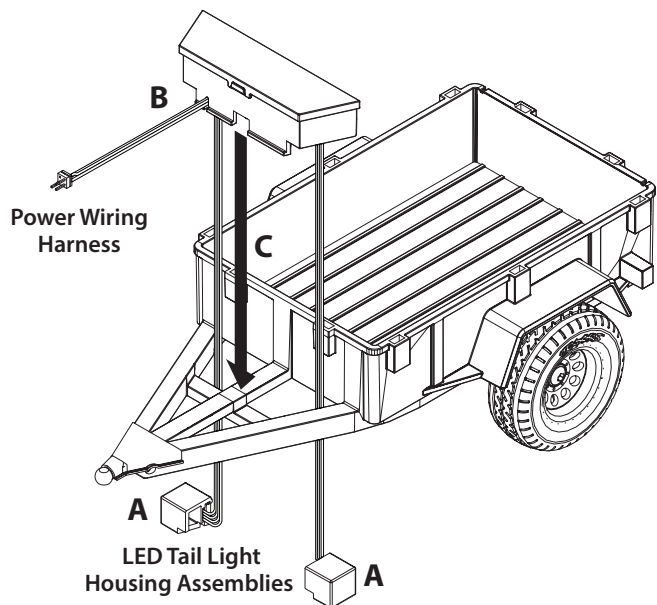

- A. Route both LED taillight wiring harnesses through the channels in the underside of the trailer frame (see Trailer Lights Wiring Diagram). Install the housing assemblies onto the left and right tail light posts with the included 3x6mm CCS (2).

B. Install the supplied rubber wire plugs (6) to secure the wiring harnesses to the underside of the trailer (see Trailer Lights Wiring Diagram).

## Trailer Lights Wiring Diagram

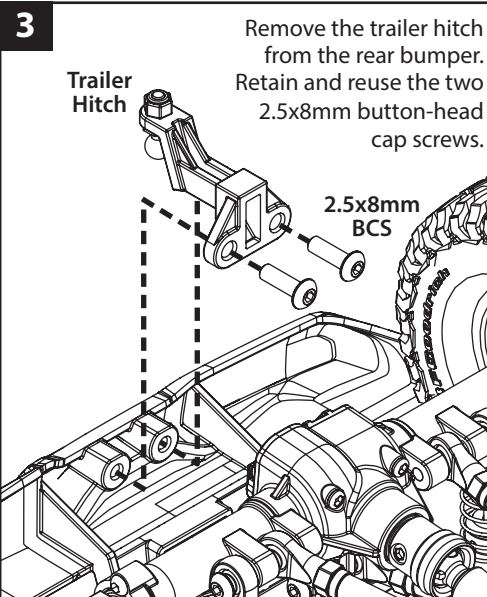
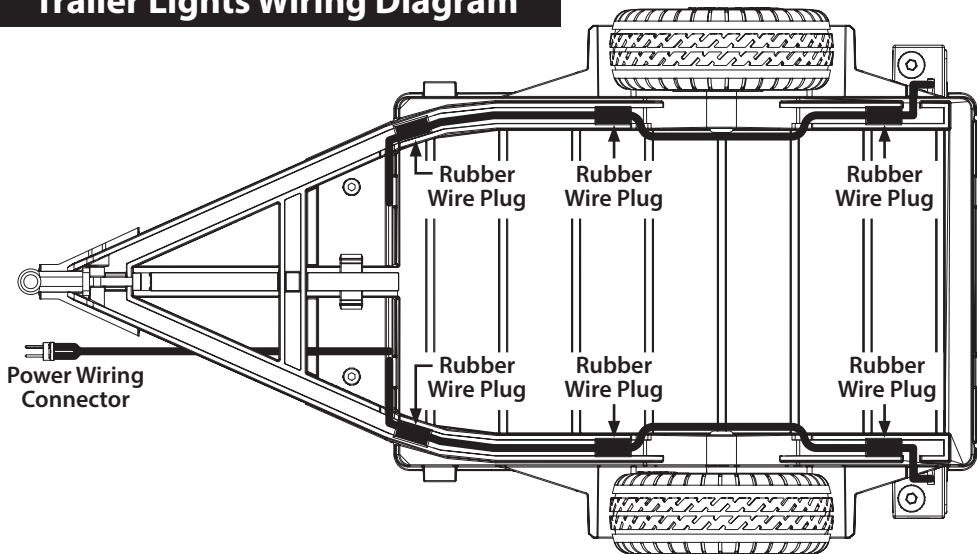

- Insert the black connector from the included Y-harness into the wire mount as shown.

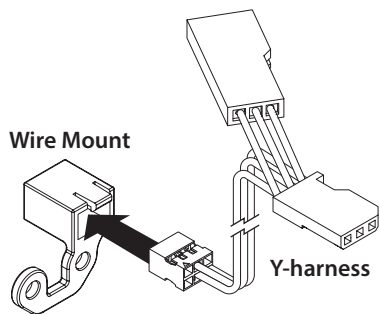

NOTE ORIENTATION

- Use the 2.5x8mm button-head cap screws from Step 3 to secure both the wire mount and the trailer hitch to the rear bumper.

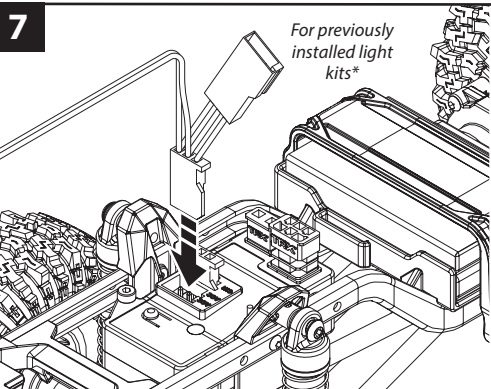
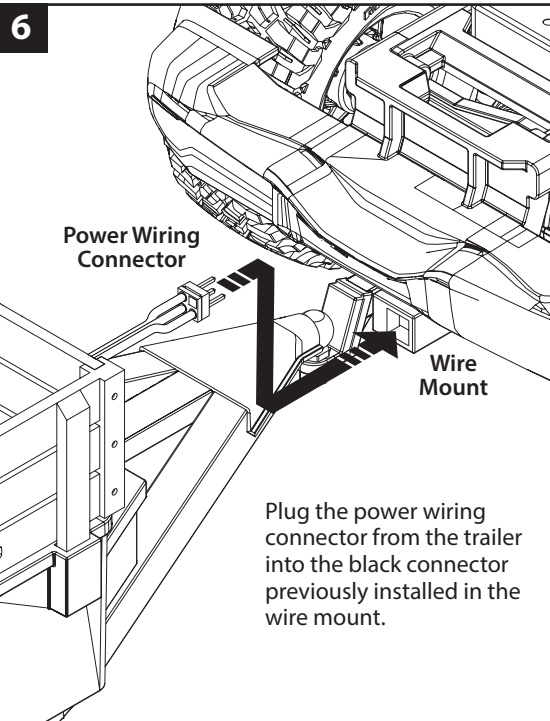
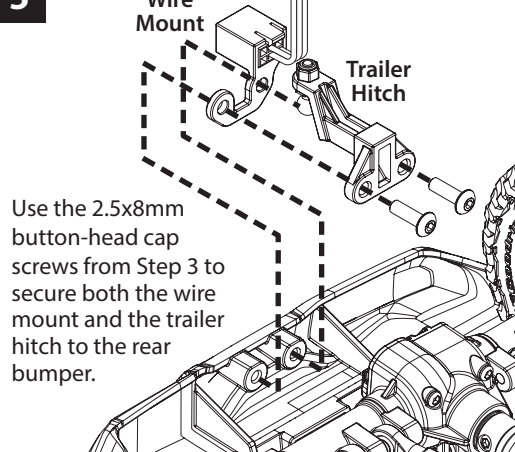

Plug the Y-harness into an open ACC port on the electronic control module (ECM). The LED lights will turn on when the ECM is powered on by plugging in the battery.

*\*If there are no open ACC ports on the ECM due to previously installed light kits, unplug one of the connectors from the previously installed light kit, plug that connector into the Y-harness, and then plug the Y-harness into the ECM.*

If you have questions or need technical assistance, call Traxxas at  
**1-888-TRAXXAS**  
 (1-888-872-9927) (U.S. residents only)