



ES09 MA

Analog servo



Good news! EMAX have designed a series of specific swash servos for 450 helicopters. And now you will be able to have a high quality swash servo for your 450 helicopters with a very attractive price! Below are some key features:

CHARACTER



increase torque and speed to a higher level than Stronger gear set and case made of engineering plastics.



Dual-bearing, and large diameter shaft design minimize the disatema and keep the servo operating smoothly for a long time.



Different structure strengthens gear hardness, maximizes transmission efficiency, and provides a higher torque from same drive current.



Applies NOBLE potentiometer which assures the coherence.

Parameter:

Mini SERVO (ES09MA) SERIES

SERVO ES09MA SPECIFICATIONS

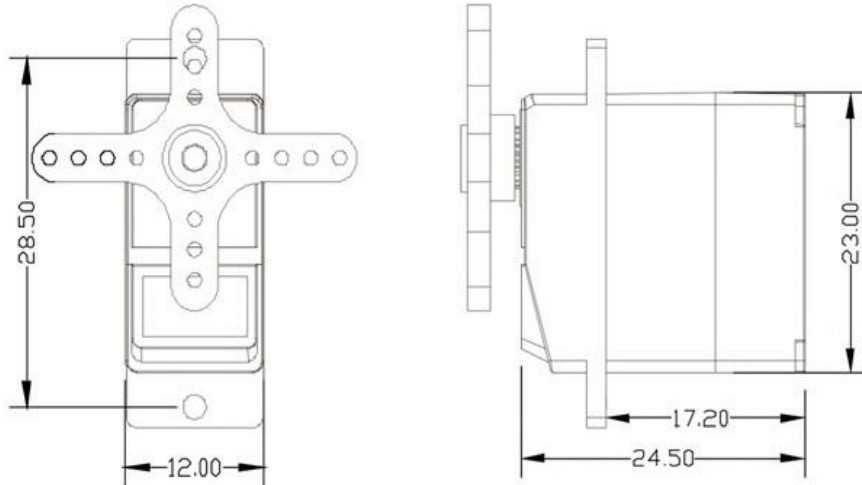

Operating Voltage:	4.8~6.0V	
STD Direction:	Counter Clockwise / Pulse Traveling 1500 to 1900usec	
Stall Torque:	4.8V	2.3 Kgf.cm
Operating Speed:	4.8V	0.10 Sec/60° at no load
Stall Torque:	6.0V	2.6 Kgf.cm
Operating Speed:	6.0V	0.08 Sec/60° at no load
Dimensiones:	23.0X12.0X24.5 mm	
Weight:	14.8g	
Plug Available	FUT ;JR	
	Metal ,Analog	

What's in the box:
ES09MA Servo
Servo arms

