



Front Bumper/Winch Fairlead Installation Instructions - Mercedes-Benz® G 500® and G 63®

Covers Part #8868

Kit contents:

- Front bumper
- Winch fairlead
- 2.5x10mm cap head screws (6)

Tools needed:

- 2.0mm hex wrench
- Body scissors (part #3431 or #3432, sold separately)

1

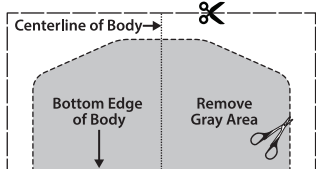

Body Template 1:1

CAUTION: RISK OF INJURY!
Use care with hobby knives, tapered reamers, and other cutting tools as they are extremely sharp and can cause severe injury, deep cuts, and/or punctures.

Body modification (Fig. A):

Before installation of the new front bumper, the vehicle body will need modification. Cut out the body template above, and then place it on the front of the body as shown. Use body scissors to cut out the section as indicated.

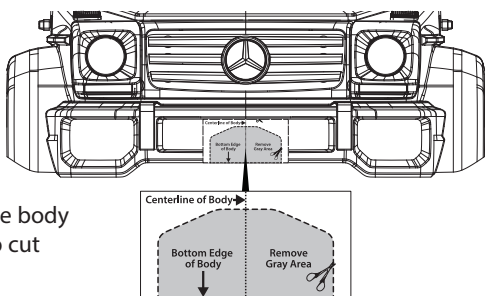

2

Remove the front skid plate and existing front bumper.

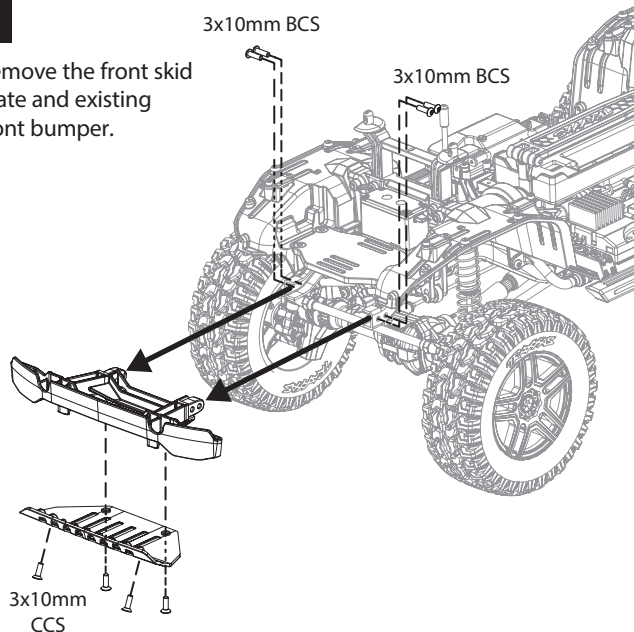

3

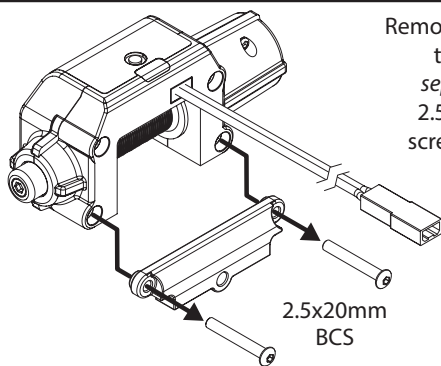

Remove the winch mount from the winch (part #8856, sold separately) by removing the 2.5x20mm button-head cap screws. Discard these screws.

4

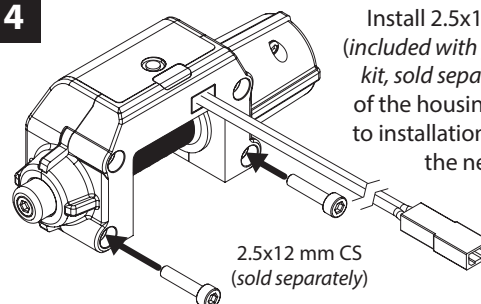

Install 2.5x12mm cap screws (included with part #8855 winch kit, sold separately) in the rear of the housing as shown prior to installation of the winch on the new front bumper.

5

Attach the winch and the included fairlead to the new front bumper using the supplied 2.5x10 cap screws (6). Install the new front bumper and reinstall the front skid plate and reinstall the screws from step 2.

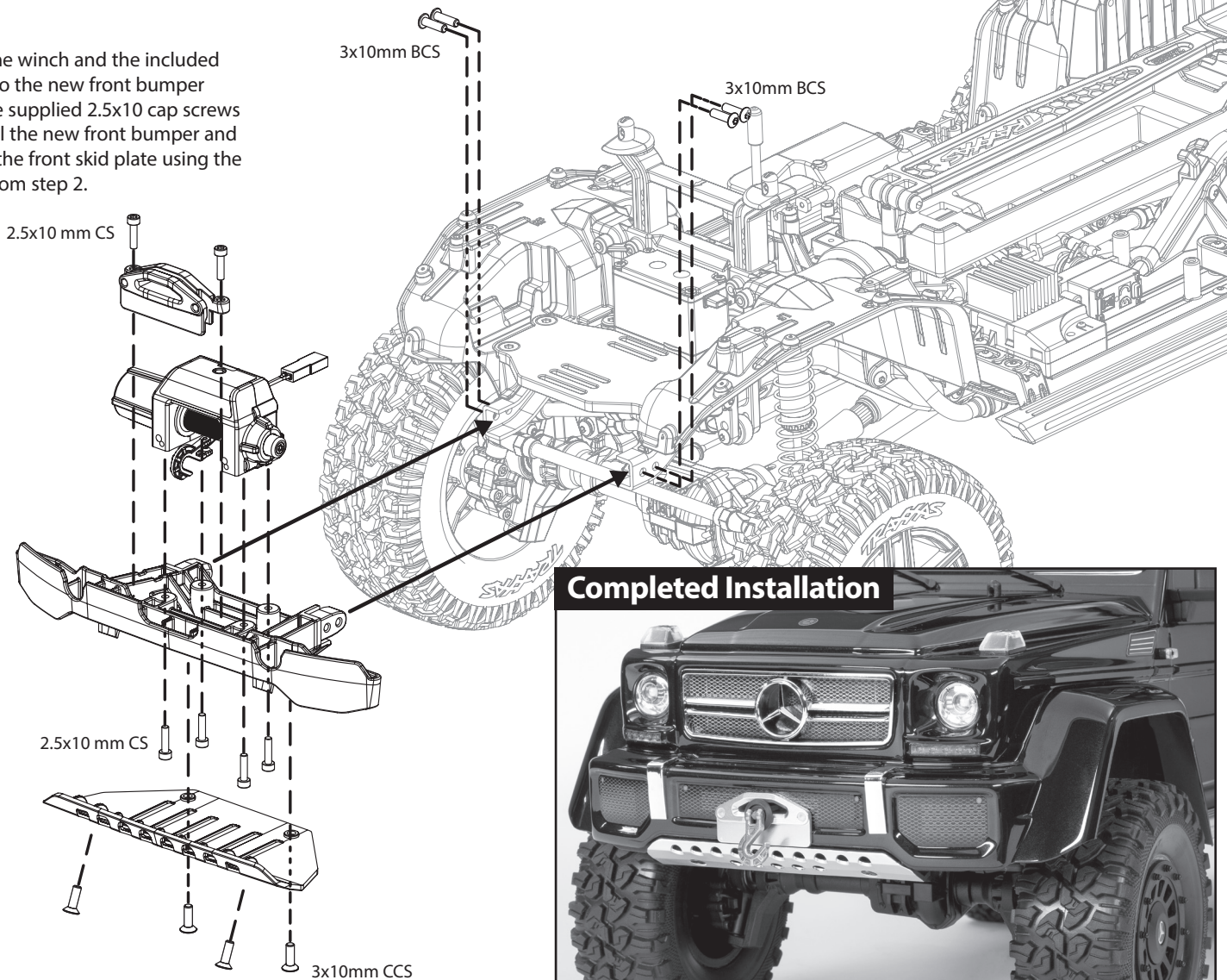

Completed Installation

