



BGL-3G-A V2 Instruction Manual

Thanks for choosing Bigaole 3G-A V2 Unit. 3G-A V2 Unit is a small and light 3-axis gyro with high performance. 3G-A V2 supports 3 types of planes, the normal one, flying wing and V-Tail. With latest MEMS technology, 3G-A V2 unit provides excellent stability, flexibility and reliability and make the flight follow the pilots' operation more exactly through auto-correcting for aileron, elevator and rudder. It can be used on electronic airplane and engine airplane.

1、 Specification and Features

Specification:

Dimensions: 36mm*28*6mm

Weight: 15g

Operating voltage: DC 3.5V-9V

Operating current: 20mA

Maximal angular velocity: 800 degrees/sec

Servo compatibility: 1.52ms analog servo/1.52ms digital servo

Radio compatibility: PPM/PCM/2.4G

Operating Temperature: -15°C-60°C

Features:

- ◆Support single/double Aileron
- ◆Easy switch within AVCS mode, Normal mode and Gyro Off mode
- ◆Compact, light, could be used in normal airplane, flying wing and V-tail, with easy switch change.
- ◆Excellent optimized for 3D flight without undermining stability.
- ◆Easy set-up, separated adjustment of gain for aileron, elevator and rudder.
- ◆The best gyro for engine airplane by using metal case.

2、 Function and connection.

Signal Input

AIL1 IN Signal input for AIL1
 ELE Signal input for Elevator
 RUD Signal input for Rudder
 SW Locking mode switch
 AIL2 IN Signal input for AIL2

Signal Output

AIL1 OUT Signal output for Aileron 1
 ELE OUT Signal output for Elevator
 RUD OUT Signal output for Rudder
 AIL2 OUT Signal output for Aileron2

Gyro Gain Adjustment Knob

AIL Gain Adjustment for Aileron

RUD Gain Adjustment for Rudder

ELE Gain Adjustment for Elevator

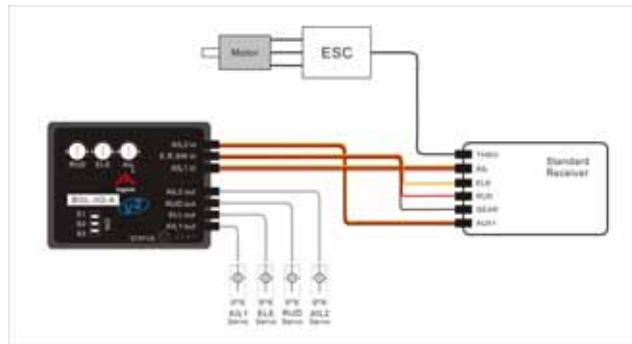
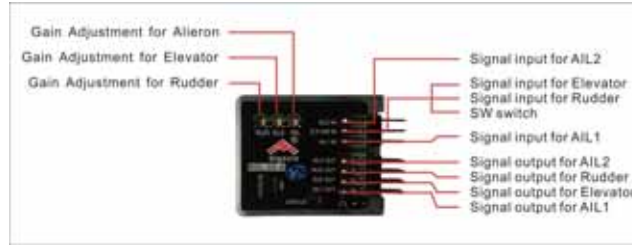

2.1 When AIL2 IN is not connected to the receiver,

◆AIL1 OUT and AIL 2 OUT are exactly the same, the travel can't be adjusted, they are equivalent of a Y line function, controlled by AIL1 input signal.

2.2 When AIL2 IN and AIL1 IN are connected to the receiver,

◆AIL2 OUT is controlled by AIL1 input signal, and AIL1 OUT is controlled by AIL1 input signal.

◆AIL sticker can control AIL2 OUT channel servo's normal/ reverse direction and AIL1 OUT channel servo's normal/ reverse direction and these channel servo's ATV.

◆Taking SPEKTRUM DX8 as an example, the setting method is as below,

a. WING TYPE—WING—DUAL AIL

b. SERVO—TRAVEL, you can adjust the RTGHT AIL or LEFT AIL's ATV.

SERVO—REVERSE, you can adjust the RIGHT AIL or LEFT AIL's normal/ reverse direction.

AIL2 OUT and AIL1 OUT channel gyro's compensation direction are same.

◆Model Selection

S1/S2/S3 for Corresponding Model

	S1	S2	S3	AIL OUT	ELEV OUT	RUDD OUT
Setting(Gyro Nor/Rev)	0	0	0	-	-	-
Normal Airplane	1	0	0	AIL Servo	ELE servo	RUD servo
Flying Wing(delta)	0	1	0	Left wing servo	Right wing servo	RUD servo
V-Tail	0	0	1	AIL servo	Left wing servo	Right wing servo

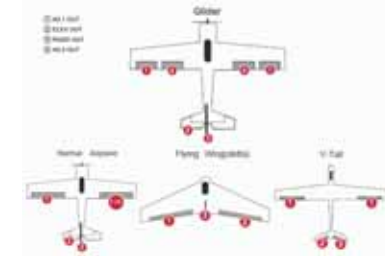

3、 LED Status

Initialization	Blue flashes rapidly for 3 secs after powering on	Initialization is normal, please don't move the plane
	After initialization, the blue LED will flash some times	Flash one time for normal model, two times for flying wing(delta) and three times for V-Tail
	Fast circular flashing of red LED after initialization	Initialization failed
Working Status	Blue LED steady on	Normal Mode
	Red LED steady on	AVCS Mode
	Both LEDs Extinguished	Gyro Off
Setting(Gyro Nor/Rev)	Entering into setting Mode,the Red/Blue LED flashes	Signal of receiver undetected

4、 Installation of 3G-A V2

◆The 3G-A V2 unit must be installed in a flat and stable platform close to the center of gravity in your plane, the connecting method refers to the following diagram: (diagram 1)

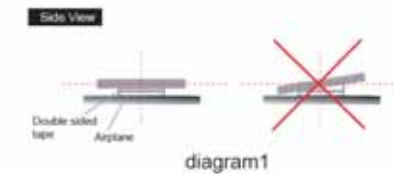

◆When the BGL-3G-A V2 is used on engine airplane, the double sided tape should be put like this(diagram 2), reduce vibration caused by engine.

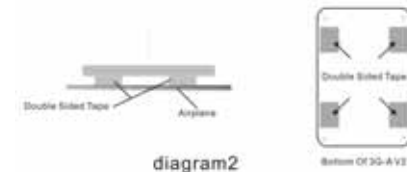

◆The 3G-A V2 unit must be installed towards forward in a level platform as showing in diagram 3

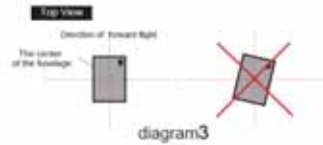

Transmitter Setting

Turn on the transmitter and create a new model, set the trims and sub-trims of all channels to zero, making sure that all mix-function are off.

5. Gain Adjust

a. trimming potentiometers AIL,ELE and RUD correspond to the gain adjustment for those three channels, clockwise to increase and anti-clockwise to reduce.

b. Gyro Compensation Direction Verification

◆Connect the gyro, receiver and servo correctly;

◆Choose correct model for your airplane by dialing S1, S2 and S3;

◆Pick up the aircraft around the pitch axis ,the roll axis and the yaw axis to check if the direction of movement of the rudder (control surface) is correct otherwise enter into Setting Mode to adjust the compensation direction of gyro.

◆Move the sticks of aileron, elevator and rudder separately, to see if the moving direction of rudder(control surface) is correct, otherwise adjust the normal/reverse of corresponding channel on your transmitter.

◆Move knobs of AIL,ELE and RUD on the gyro ,to adjust the gain of AIL,ELE and RUD to the middle position ,then pick up the aircraft around the pitch axis ,the roll axis and the yaw axis to check if the reacting amount of rudder(control surface) is appropriate.

Gyro Gain Correction Diagram

1. Rotating the plane around pitch axis, check the correction of gain for elevator as showing in the diagram 1 and 2.

2. Rotating the plane around the roll axis, check the correction of gain for aileron as showing in the diagram 3 and 4.

3. Rotating the plane around the yaw axis, check the correction of gain for rudder as showing in the diagram 5 and 5.

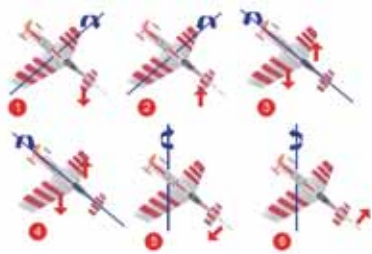

6. Switch of AVCS Mode.

SW is the switch to change mode of AVCS for flight. If use 2-section switch, it just can change between AVCS and Normal mode. For 3-section switch, apart from the AVCS and Normal mode, it has an additional Gyro off Mode, refer to the following table:

Flight Mode	Range of switch	Signal Pulse Width	LED Status
Non-Locking	Less	1320US	Blue on
Gyro Off (AVCS)	Middle	1520+/-200US	Off
Locking	More	1720	Red on

7. Stick Centering Calibration

First, to get the best performance, centering function is required. Make the stick in your transmitter to be centered and then enter into Setting Mode to calibrate. When you use the 3G-A V2 unit for the first time, or change your transmitter, the calibration of stick center is required, after centering, all servos will be centered automatically. The center of aileron, elevator and rudder could be obtained by adjusting the linkage rods. The function of sub-trim in your transmitter could not be used.

8. Setting Process (Gyro Nor/Rev)

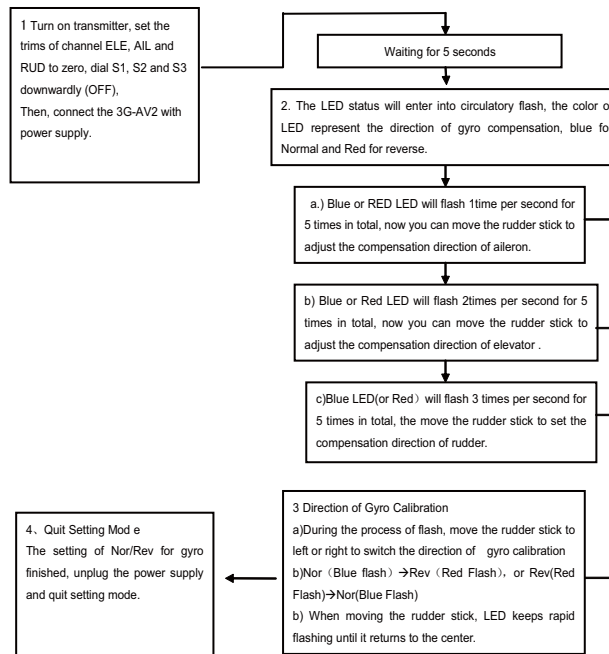

9. First Flight

For the first flight, please check if the direction of gyro compensation, direction of control by stick are correct, and set the gain to a small volume, and after times of flight test, then set it to a appropriate volume, in order to get the most excellent flight performance.

10. Troubleshooting

◆Airplane swings regular, rapid and alternately

Decrease the gyro gain.

◆Airplane swings irregularly.

Check if the vibration of engine with airframe is too much, reduce the vibration ,use soft double-sided foam adhesive to install the gyro. .

◆Airplane rotates irregularly, side tumbling or overturning after taking off.

Check if the direction of movement of AIL, ELE, and RUD are correct.

Move sticks of Aileron, Elevator and Rudder separately to check if the directions of movement of rudder (control surface) are correct.

◆Rotate on a direction slowly and continually.

Check if the installation of rudder (control surface) stick is level, adjust the center of servo.

Attention:

1. Checking that the mixing of flying wing or v-tail has been disabtrim change within the transmitter as 3G-A V2 has already had these functions in .

2. When it used on the engine airplane, please refers to diagram 2

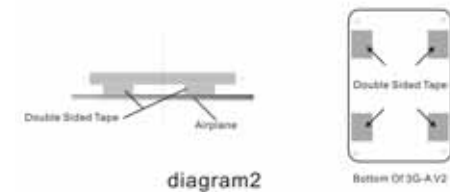

3. BGL-3G-A V2 has to re-learn the center position after making a trim or subtrim change within the transmitter, or the servos may move to the full left or full right when switching to AVCS mode. To do this ,please quickly flip the flight mode switch two or three times between Normal mode and AVCS mode per second.